

Basic optics for microscopy and image formation

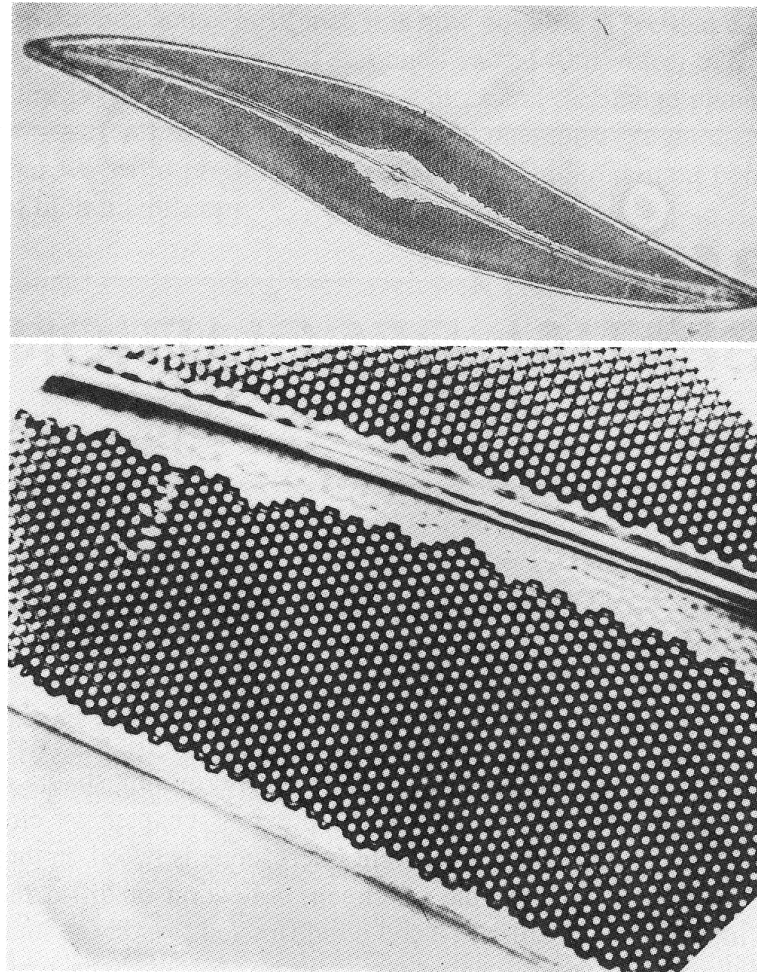

Principles of Microscopy and Microscope Anatomy

Ian Dobbie - ian.dobbie@bioch.ox.ac.uk
x13323 micron@bioch.ox.ac.uk

Buy this book for your lab:

J. B Sanderson, Understanding Light Microscopy -
RMS - Royal Microscopical Society

Visit these websites:

<http://www.microscopyu.com>

<http://www.olympusmicro.com>

Key points

- Basic understanding of refraction and diffraction, and properties of lenses
- Understanding of two different sets of conjugate planes, especially importance of objective back-focal plane
- Understanding of factors affecting image resolution

What a microscope needs to do

- Magnify things
- Resolve points which are close together
- Collect as much light as possible (esp. for fluorescence)
- Do all of the above while introducing as little distortion as possible

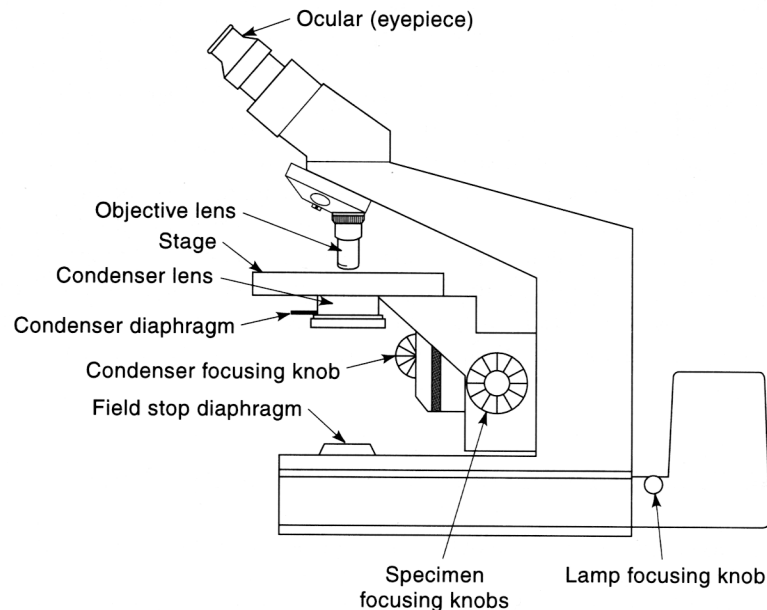

We need to understand the nature of light

- Image formation in the light microscope depends exclusively on the interactions of light with matter
- **Diffraction**: scattering of the incident illuminating light by the detailed substructure with the specimen
- **Refraction**: "bending" of light, by a lens, which causes scattered light to converge, to form an image
- **Interference**: Light combines depending on its relative phase

Electromagnetic Wave

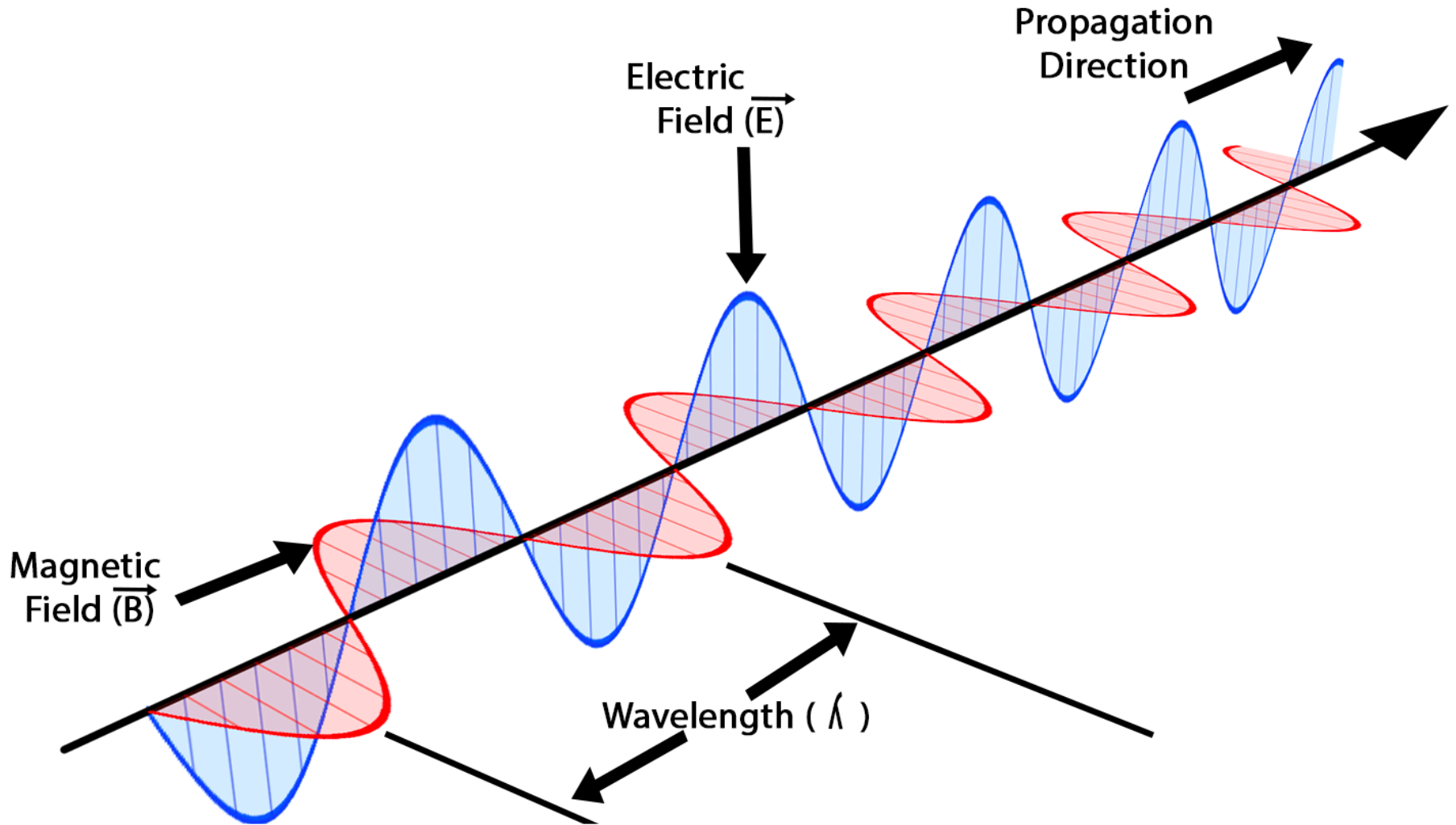

The EM spectrum

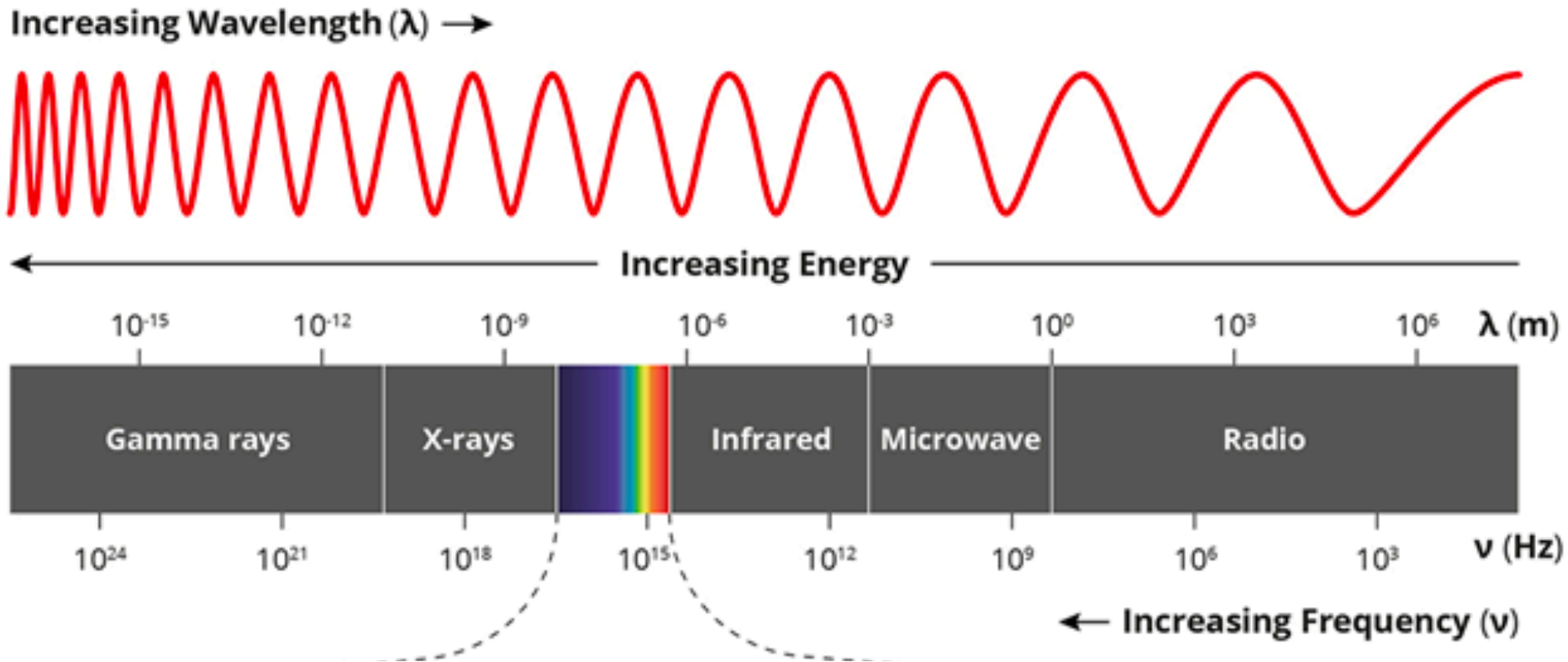

How lenses work

- Refraction--the "bending", or change in the direction, of light
- Explaining refraction doesn't require the "wave" formalism, just the rays
- The speed of light depends on the medium through which light is propagating
- Refraction occurs when light rays travelling through one type of medium meet an interface with another type of medium
- The extent of refraction depends on the angle of incidence (Snell's law)

$$n_1 \sin \theta_1 = n_2 \sin \theta_2$$

Here the light ray is *orthogonal* to the interface

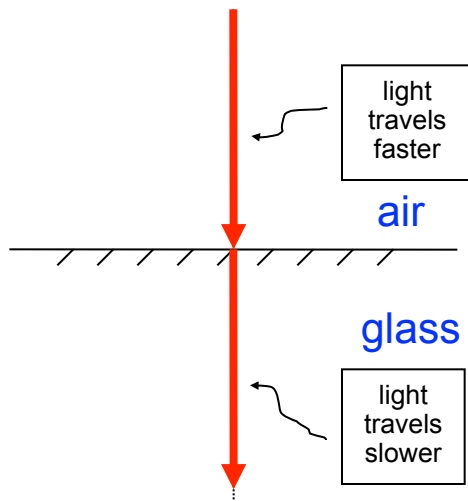

Here the light ray is *oblique* to the interface

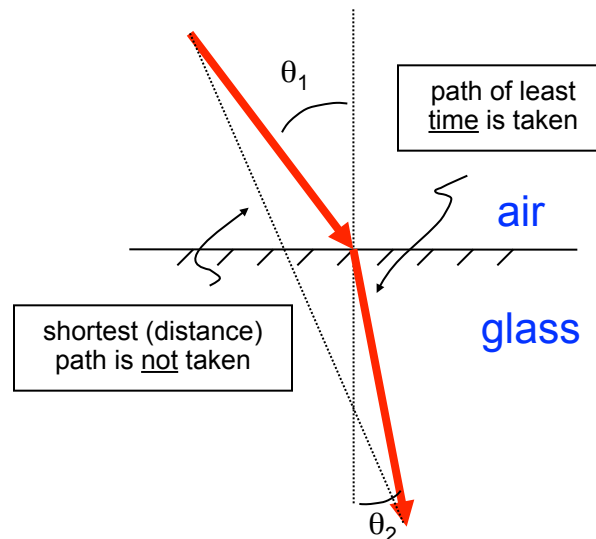

More dense materials have higher refractive indices:

Air	1.0003
Water	1.33
Glycerin	1.47
Immersion Oil	1.515 (e.g.)
Glass	1.52
Flint	1.66
Zircon	1.92
Diamond	2.42
Lead Sulfide	3.91

$$n_i = c/v_i$$

Lensing occurs when the interface is curved

- Positive (convex) lenses converge light rays. Light rays that would otherwise never meet (e.g. because they are parallel, or diverging) can now do so.
- Negative lenses (concave) diverge light rays

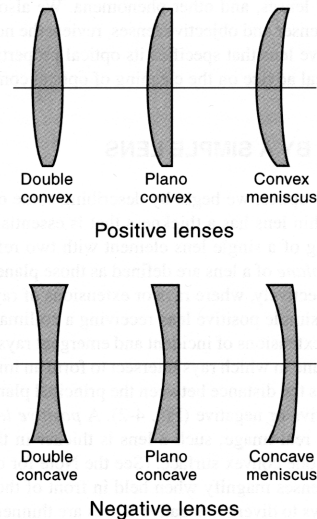
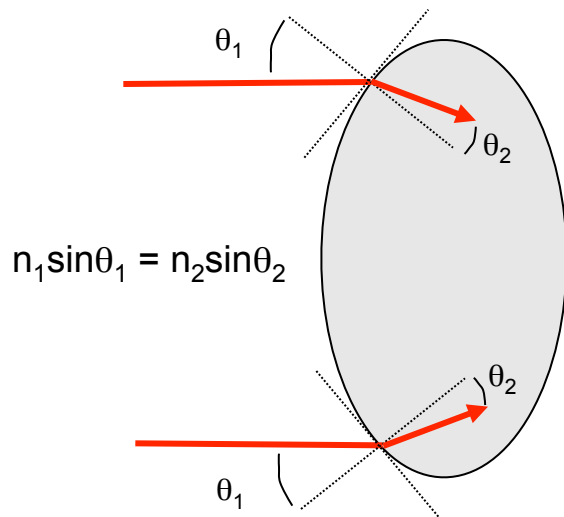

Figure 4-2
Examples of positive and negative lenses.

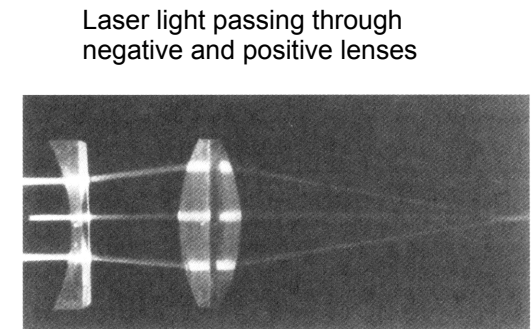

Figure 4-1
Geometrical optics of a positive lens. (From Hecht, 1998.)

Image position and magnification depend on lens curvature (focal length) and on the physical distance from the object to the lens

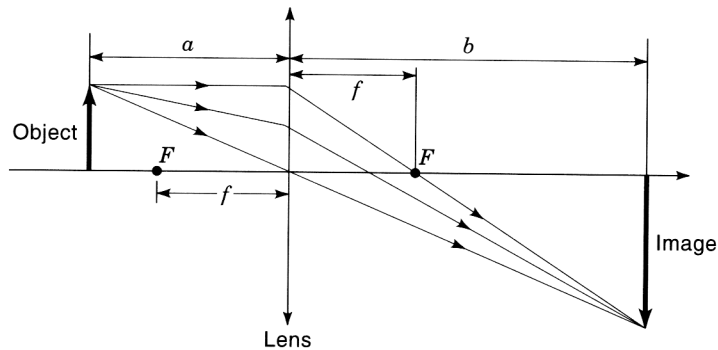

Figure 4-3

Geometrical optics of a simple lens. The focal length f , focal point F , object-lens distance a , and lens-image distance b are indicated.

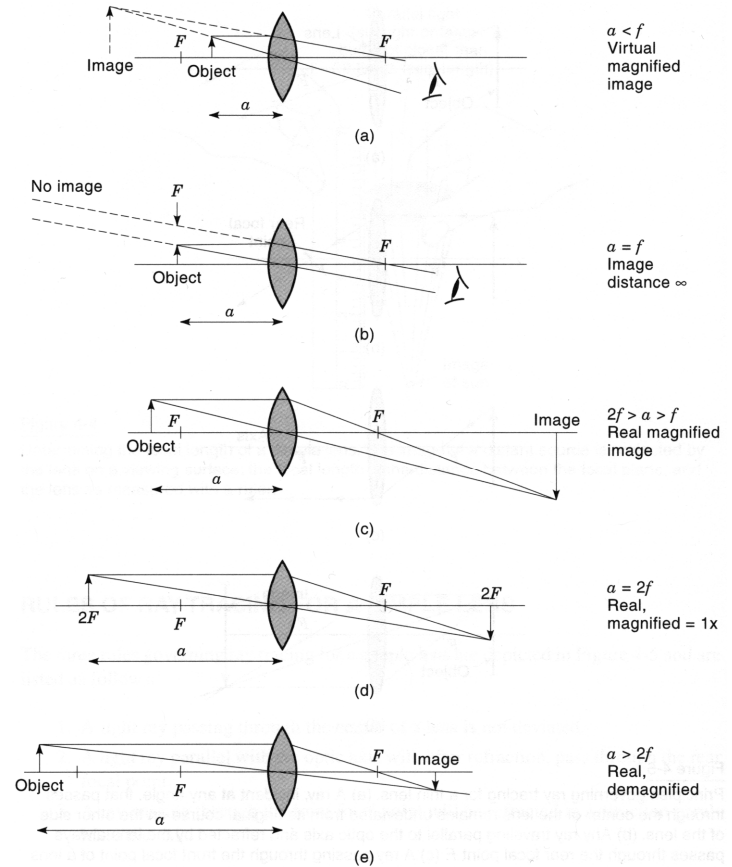

Figure 4-6

Object-image relationships. (a) $a < f$; (b) $a = f$; (c) $2f > a > f$; (d) $a = 2f$; (e) $a > 2f$.

All simple lenses have associated aberrations

- Still may encounter: *chromatic aberration* on cheap microscopes (prism effect--but can be reduced by using monochromatic light), *spherical aberration* when imaging deep into samples (e.g. embryos, even when the objective is "corrected"), *field curvature* when using bright lenses for fluorescence (but this is not a problem if you're imaging cells only in the center of the field)

More lens elements = better correction, but also possibly less light throughput

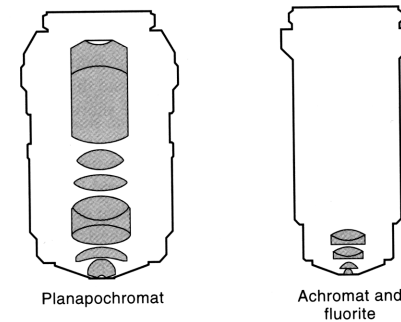
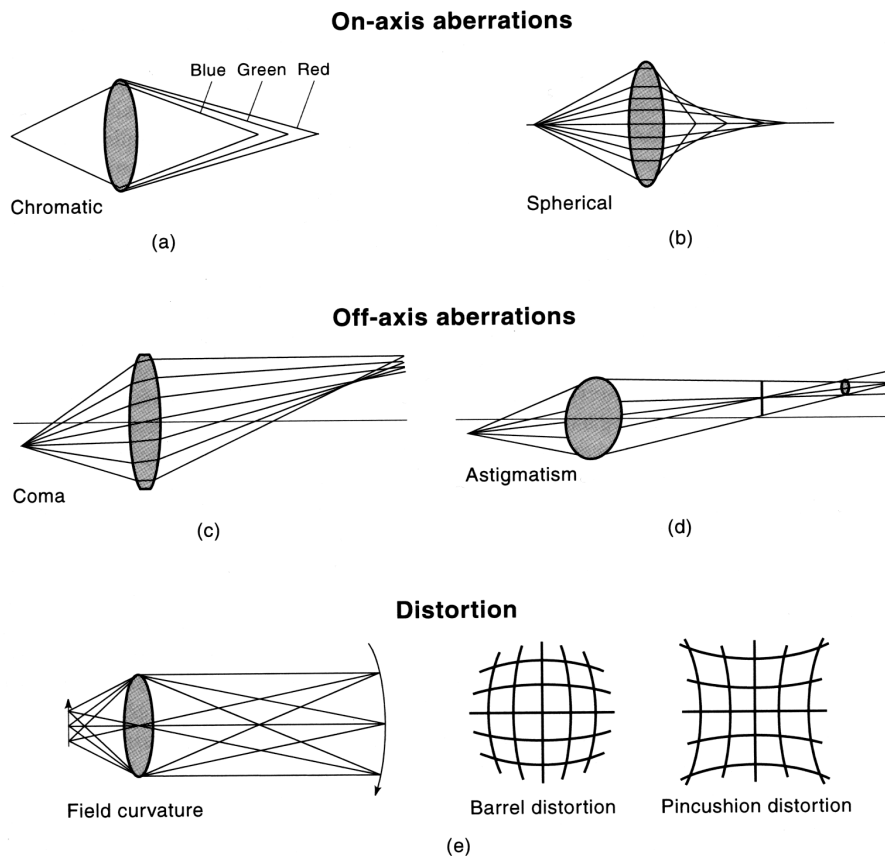

Figure 4-9
Objective lens designs. Two popular lenses for fluorescence microscopy are shown. Apochromatic lenses may contain 12 or more lens elements to give bright, flat images with excellent color correction across the visual spectrum. Fluorite lenses have fewer lens components and produce sharp, bright images. These lenses exhibit excellent color correction and transmit UV light.

Achromat = corrected for 2 colors

Apochromat = corrected for 3 colors

Plan = flat-field (although not always to full limits of field of view)

TEST BEFORE BUYING!!

Image formation in the context of a real microscope

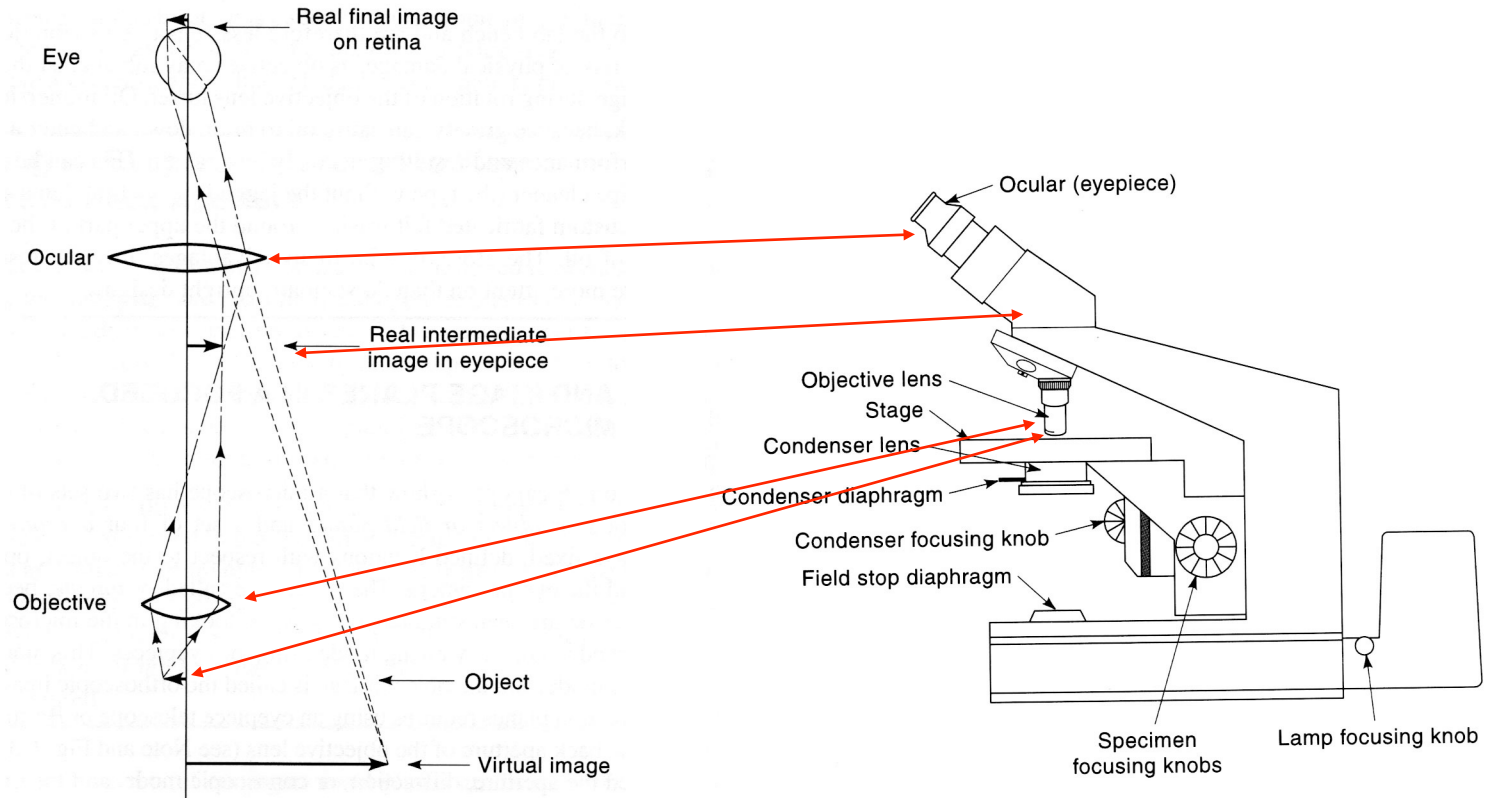

Diffraction of waves

- Scattering, altering the shape of the wave front
- At left, plane waves in water obtain a circular wavefront after passing through an aperture
- The angle of scattering of light by particles is inversely proportional to the particle size/spacing.

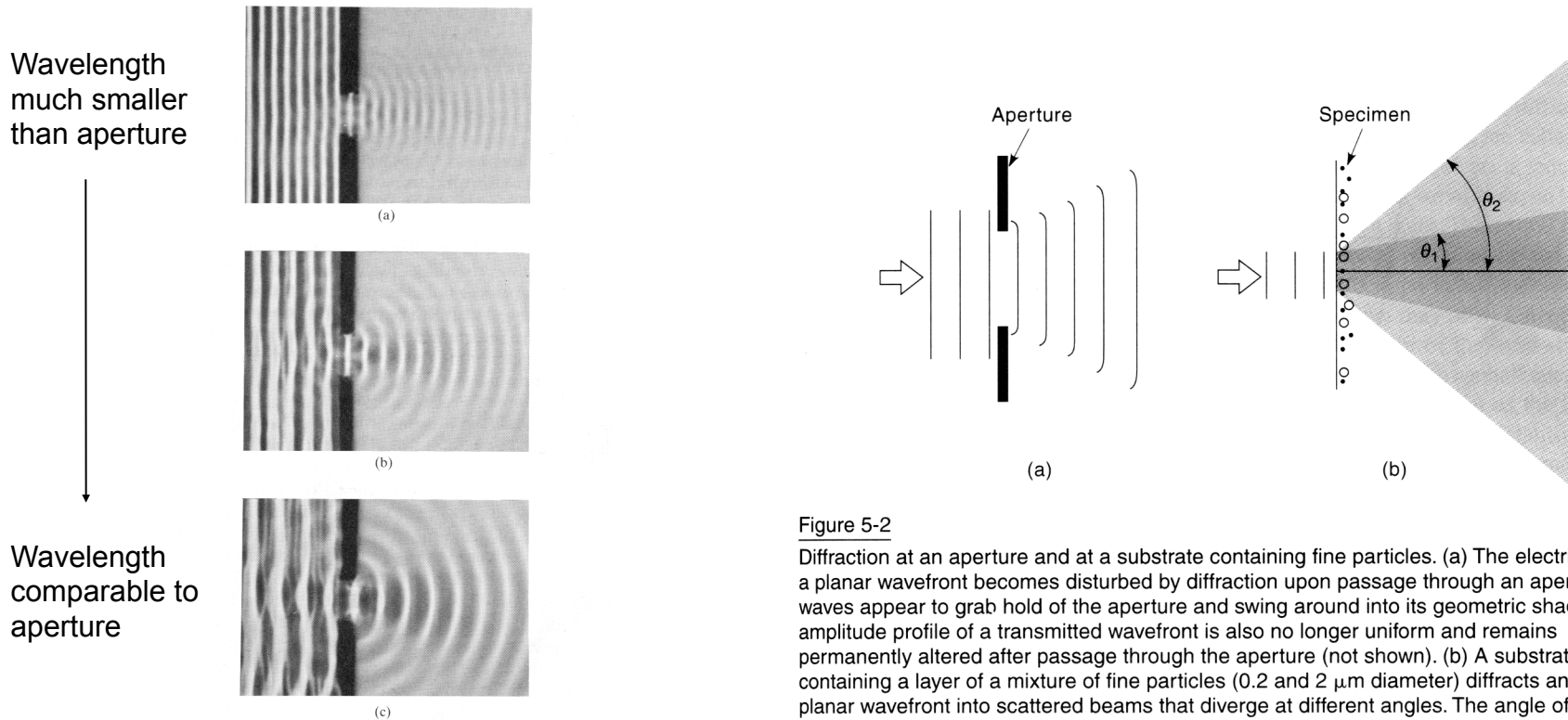

Figure 10.2 Diffraction through an aperture with varying λ as seen in a ripple tank. (Photo courtesy PSSC Physics, D. C. Heath, Boston, 1960.)

Figure 5-2

Diffraction at an aperture and at a substrate containing fine particles. (a) The electric field of a planar wavefront becomes disturbed by diffraction upon passage through an aperture. The waves appear to grab hold of the aperture and swing around into its geometric shadow. The amplitude profile of a transmitted wavefront is also no longer uniform and remains permanently altered after passage through the aperture (not shown). (b) A substrate containing a layer of a mixture of fine particles (0.2 and 2 μm diameter) diffracts an incident planar wavefront into scattered beams that diverge at different angles. The angle of spreading (θ) is inversely proportional to the size of the particles.

Diffraction and interference

- Prelude to the "two-slit" experiment
- When there are multiple sources, interference can occur

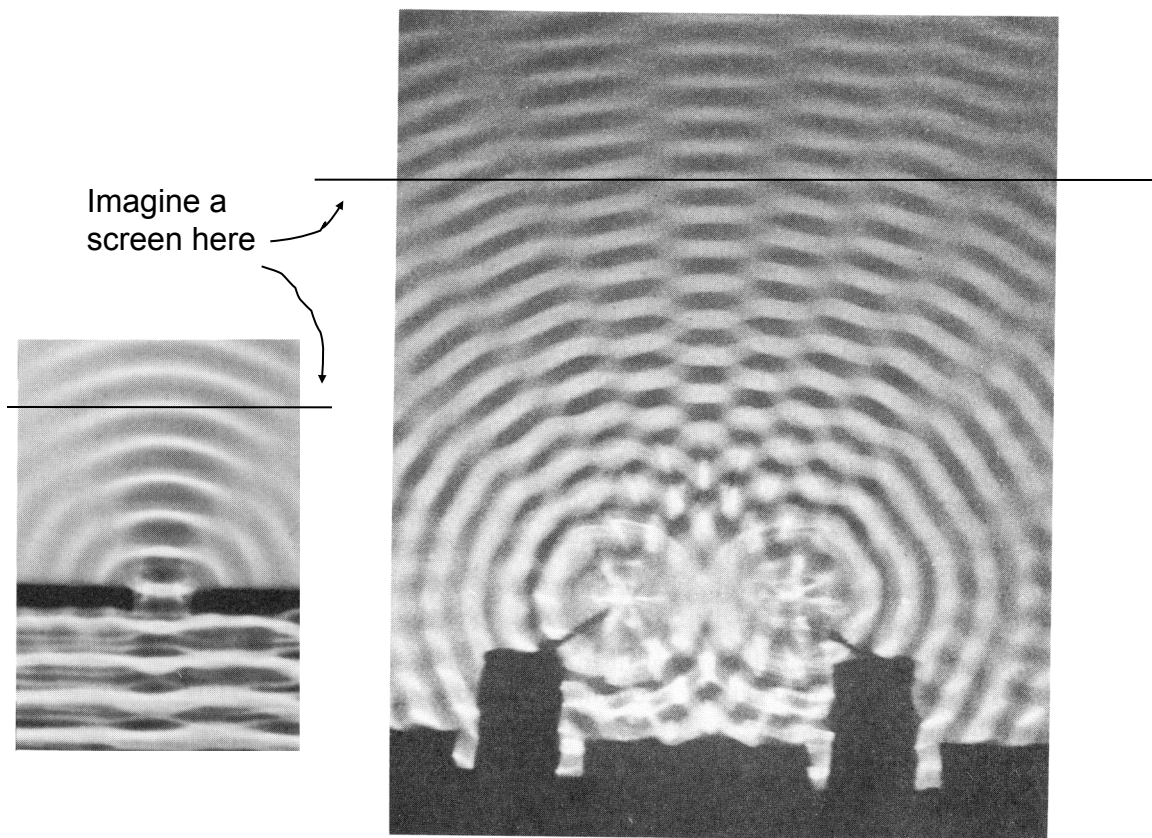

Figure 9.1 Water waves from two point sources in a ripple tank.

Constructive and destructive interference

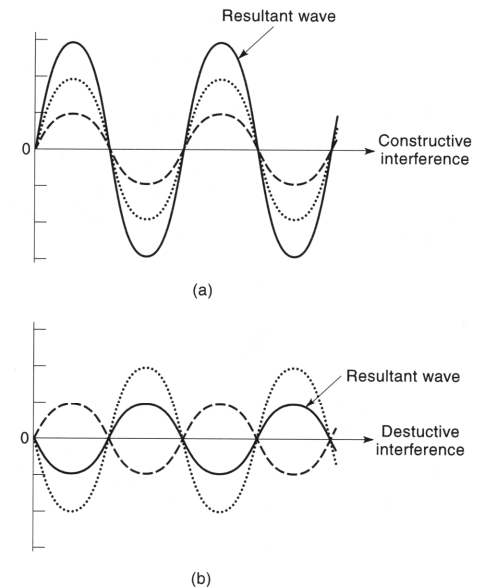

Figure 5-3

Two coincident waves can interfere if their E vectors vibrate in the same plane at their point of intersection. Two waves are shown that vibrate in the plane of the page. In these examples, both waves (dotted and dashed curves) have the same wavelength, but vary in amplitude. The amplitude of a resultant wave (solid curve) is the arithmetic sum of the amplitudes of the two original waves. (a) Constructive interference occurs for two waves having the same phase. (b) Destructive interference occurs for waves shifted in phase; if the amplitudes of the waves are the same and the relative phase shift is $\lambda/2$, the wave is eliminated.

Young's demonstration of the wave nature of light

- Demonstrated that Newton's theory of light "corpuscles" was wrong, or at least incomplete
- The diffraction pattern obtained with both slits open could be explained only by interference of waves

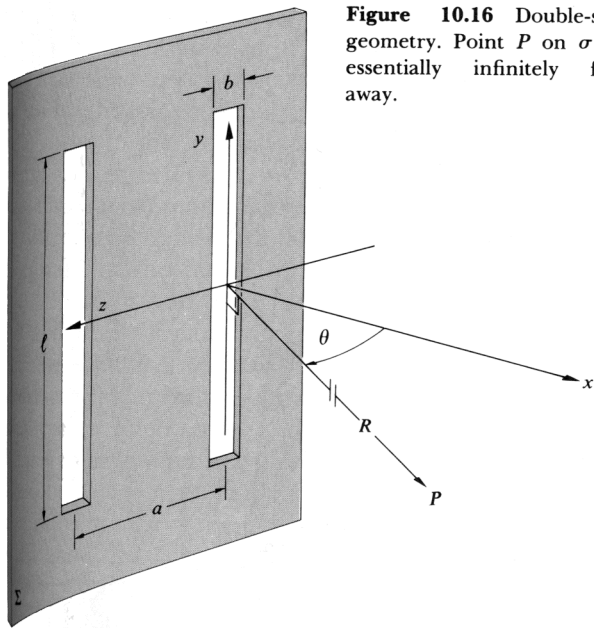

Figure 10.16 Double-slit geometry. Point P on σ is essentially infinitely far away.

Diffraction pattern from a single slit open

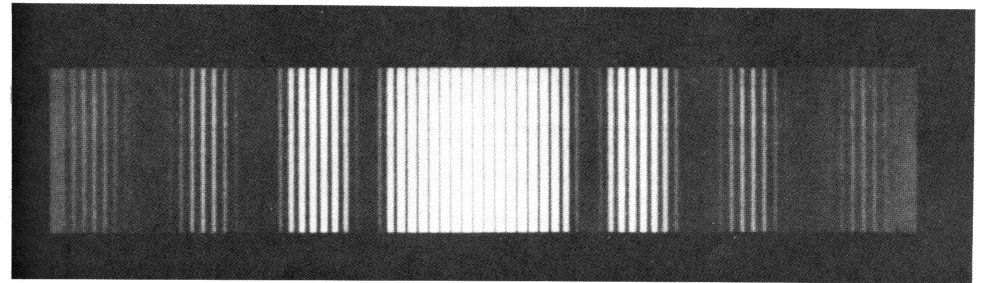
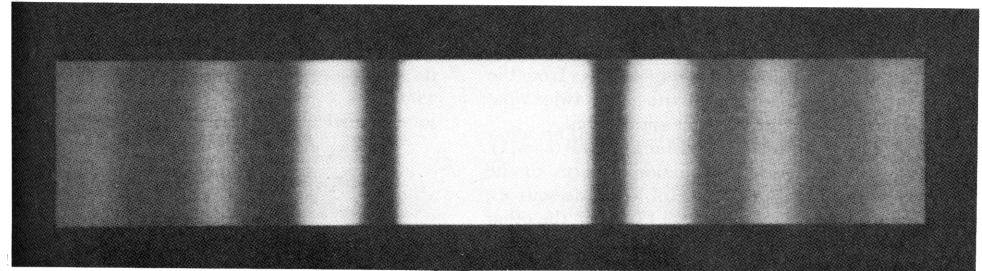

Figure 10.17 Single- and double-slit Fraunhofer patterns. The faint cross-hatching arises entirely in the printing process. (Photos courtesy M. Cagnet, M. Francon, and J. C. Thierr: *Atlas optischer Erscheinungen*, Berlin-Heidelberg-New York: Springer, 1962.)

Diffraction pattern from both slits open

The fine spacing of the lines is inversely related to the distance "a" between the two slits

Anything can create a diffraction pattern

- The individual spots in diffraction patterns of protein crystals are particularly prominent because the protein crystals have the same structure repeated infinitely, but even individual objects generate diffraction patterns (which are even more complex)

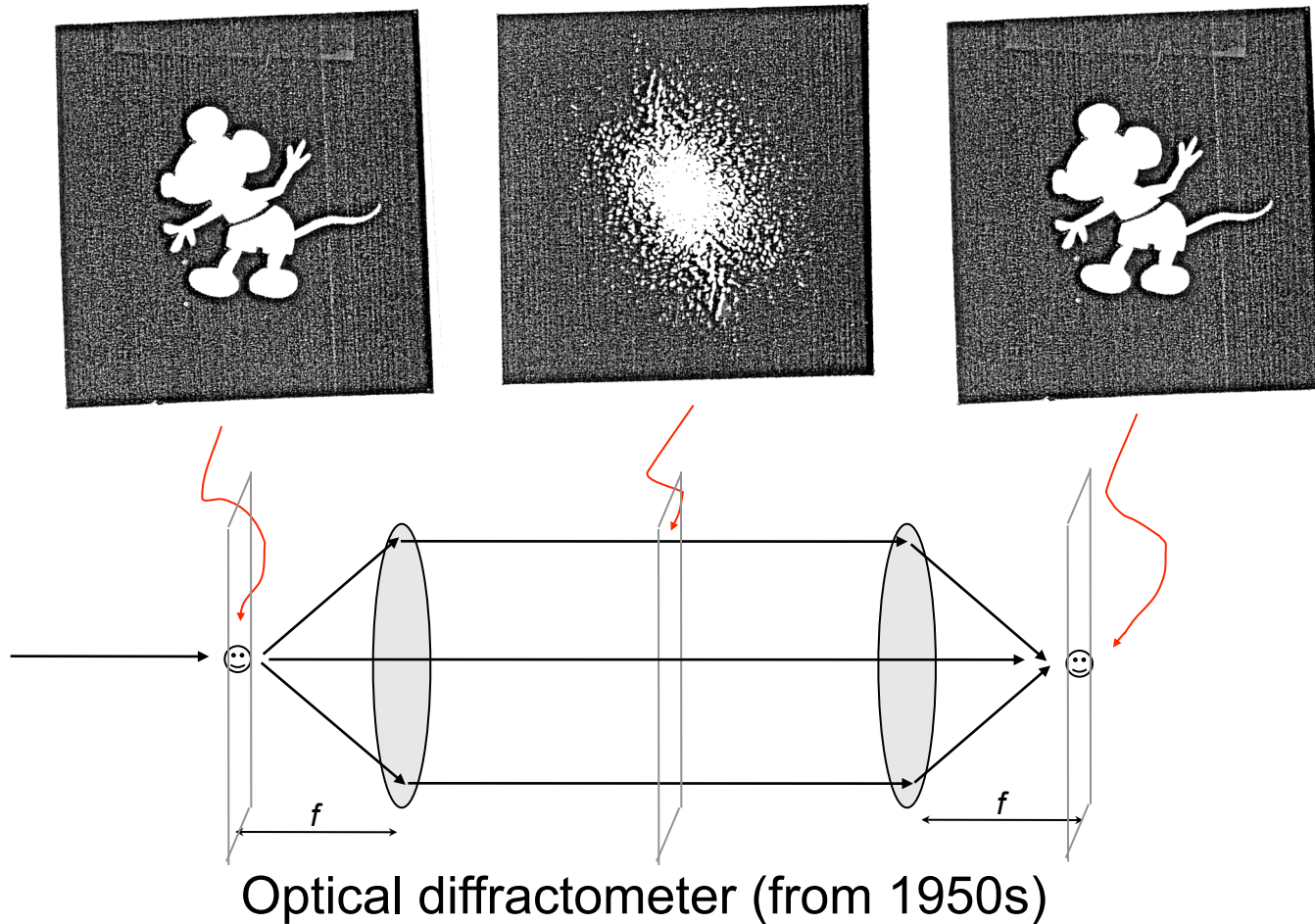

Abbe's theory of image formation

Ernst Abbe, 1840–1905. Principles of microscope and objective lens design, the theory of image formation in the microscope, and standardized lens manufacturing procedures all trace their beginnings to the work of Ernst Abbe and his collaborations with Carl Zeiss in Jena, Germany, in the 1860s. Until then, lens making was an art and a craft, but the new industrial philosophy demanded technical perfection, lens designs based on theory and research, and improvements in raw materials. At Abbe's initiative, lens curvatures were examined using an interference test with Newton's rings, and lens designs were based on Abbe's sine-squared condition to remove aberrations. He created the first planachromatic lens, and after much research, the apochromatic lens, which was commercially sold in 1886. After many false starts over a 20-year period, the research-theory-testing approach for manufacturing lenses proved to be successful. These improvements and new photographic lens designs required new types of glass with values of refractive index and color dispersion that were not then available. Abbe and Zeiss won grants and developed new glasses in collaborations with the industrialist, Otto Schott, owner of the Jena Glassworks. Other inventions were the Abbe achromatic condenser, compensating eyepieces for removing residual color aberration, and many other significant items of optical testing equipment. Abbe is perhaps most famous for his extensive research on microscope image formation and his diffraction theory, which was published in 1873 and 1877. Using a diffraction grating, he demonstrated that image formation requires the collection of diffracted specimen rays by the objective lens and interference of these rays in the image plane. By manipulating the diffraction pattern in the back aperture, he could affect the appearance of the image. Abbe's theory has been summarized as follows: *The microscope image is the interference effect of a diffraction phenomenon.* Abbe also introduced the concept of numerical aperture ($n \sin \theta$) and demonstrated the importance of angular aperture on spatial resolution. It took 50 years for his theory to become universally accepted, and it has remained the foundation of microscope optical theory ever since. Ernst Abbe was also a quiet but active social reformer. At the Zeiss Optical Works, he introduced unheard-of reforms, including the 8-hour day, sick benefits, and paid vacations. Upon his death, the company was handed over to the Carl Zeiss Foundation, of which the workers were part owners.

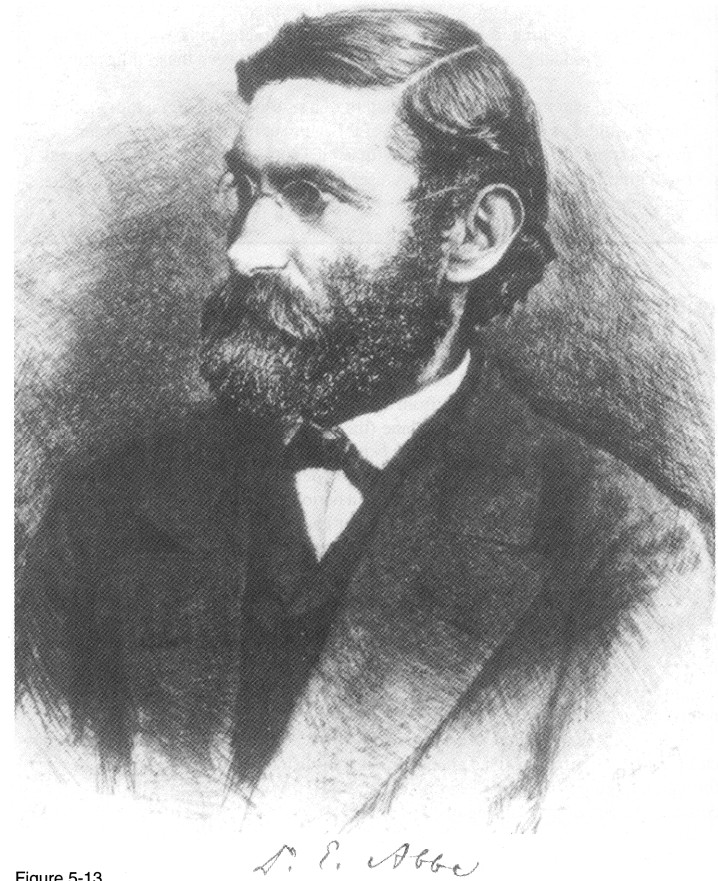

Figure 5-13

The diffraction grating

- The grating is a series of ruled lines, spaced very close together (e.g. $1000 \text{ nm} = 1 \mu\text{m}$), roughly in the neighborhood of the wavelength of light
- Gratings are made by machining (difficult) or by laser etching, or more often as plastic replicas of originals
- Gratings can be either transmission gratings (as shown) or reflection gratings (e.g. machined on a piece of metal).

Diffraction by an actual grating.
Each of the different orders is "made up" of parallel rays (converging only at infinity)

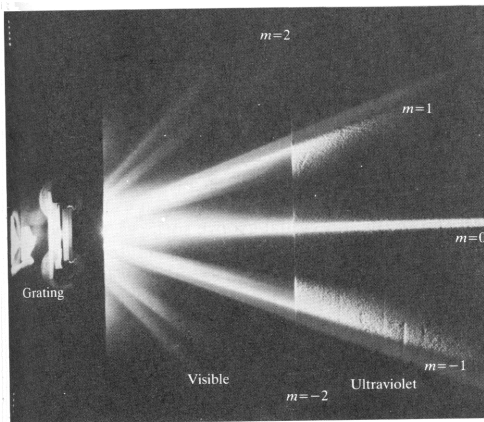

Figure 10.35 Light passing through a grating. The region on the left is the visible spectrum, that on the right, the ultraviolet. (Photo courtesy Klinger Scientific Apparatus Corp.)

Addition of a lens to the system allows the spots to be nicely in focus at a finite distance from the grating

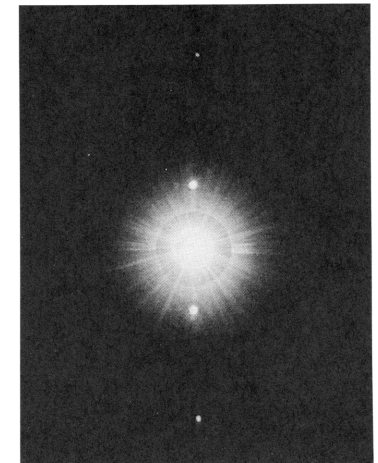
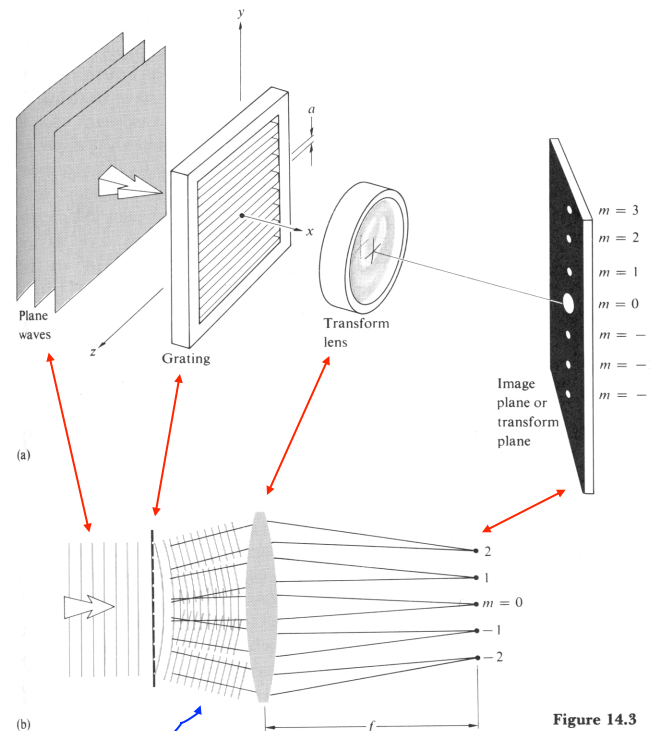

Figure 14.3 Diffraction pattern of a grating. (Source unknown.)

Diffraction by a grating

Abbe's experiments with gratings helped him to develop his theory of image formation, which is what we use today.

$$d \sin \theta = n \lambda$$

(where $n = 0, 1, 2$, etc.)

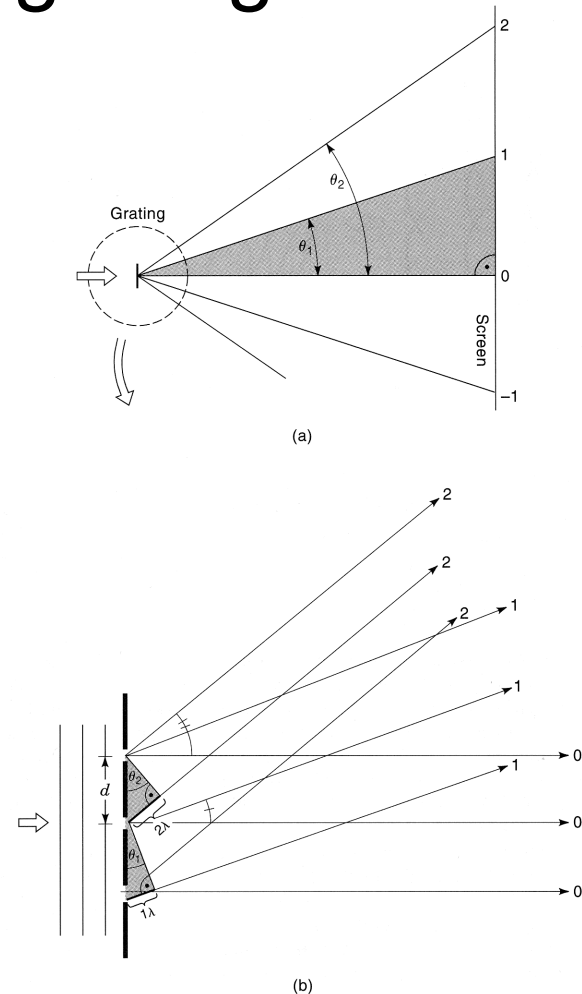

Figure 5-9

Dependence of scattering angle on grating spacing and wavelength. (a) Rays from a diffraction grating projected on a viewing screen. The angle of scattering of the 1st- and 2nd-order rays is shown as θ_1 and θ_2 . The grating and 1st- and 2nd-order spots define a right triangle that includes θ_1 and is congruent with a triangle that can be delineated at the grating as shown in (b). (b) The diffracted rays at the grating define a right triangle that includes diffraction angle θ . For the 1st- and 2nd- etc.-order diffracted rays, the base of the triangle is an integral number of wavelengths, $1\lambda, 2\lambda$ etc. Thus, the angle of diffraction depends on two parameters: the grating spacing d and wavelength λ .

Abbe theory

Abbe's big idea: "The microscope image is the interference effect of a diffraction phenomenon"

Image formation depends on interference between non-diffracted light (0th order) and diffracted light (1st order and higher order as well)

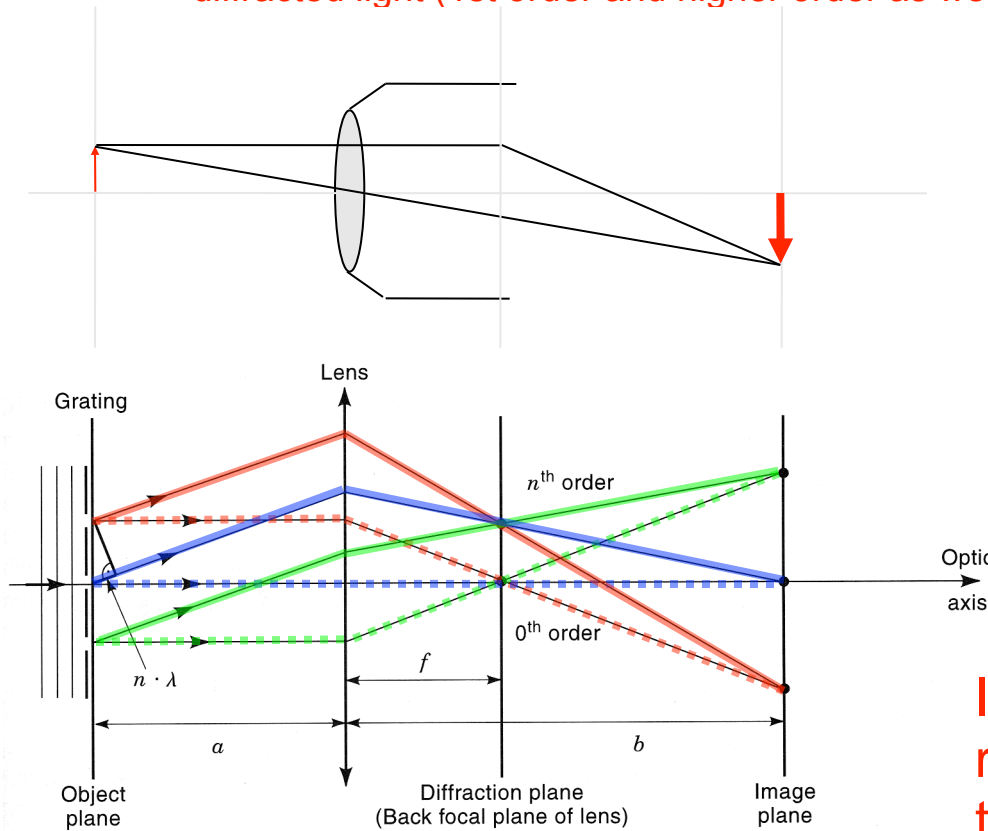

Figure 5-14

Abbe's theory for image formation in a light microscope. An objective lens focused on a grating ($2f > a > f$) in the object plane produces a magnified real image of the grating in the image plane. The diffraction plane is located at $1f$ in the back aperture of the lens. An incident planar wavefront is shown. Diffracted n^{th} -order and nondiffracted 0th-order rays are separated in the diffraction plane, but are combined in the image plane.

Interference

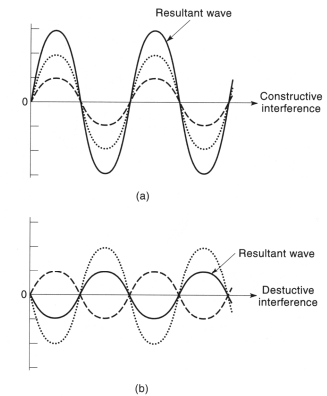

Figure 5-3
Two coincident waves can interfere if their E vectors vibrate in the same plane at their point of intersection. Two waves are shown that vibrate in the plane of the page. In these examples, both waves (dotted and dashed curves) have the same wavelength, but vary in amplitude. The amplitude of a resultant wave (solid curve) is the arithmetic sum of the amplitudes of the two original waves. (a) Constructive interference occurs for two waves having the same phase. (b) Destructive interference occurs for waves shifted in phase; if the amplitudes of the waves are the same and the relative phase shift is $\lambda/2$, the wave is eliminated.

In this sense, a lens serves to recombine light diffracted from the specimen such that the diffracted light interferes with itself in a manner that recreates an image of the specimen

Diffraction from closer spacing is at higher angles

- So if two substructures in an object are very close together, the "information" about their relative closeness will be a "high-angle" diffraction spot, i.e., further away from the undiffracted, 0th order spot.
- To get "high-resolution" images recreated from the diffraction spots, we need to collect the high-angle diffracted scattering

$$d \sin \theta = n \lambda$$

(in this instance, only $n = 1$ is shown)

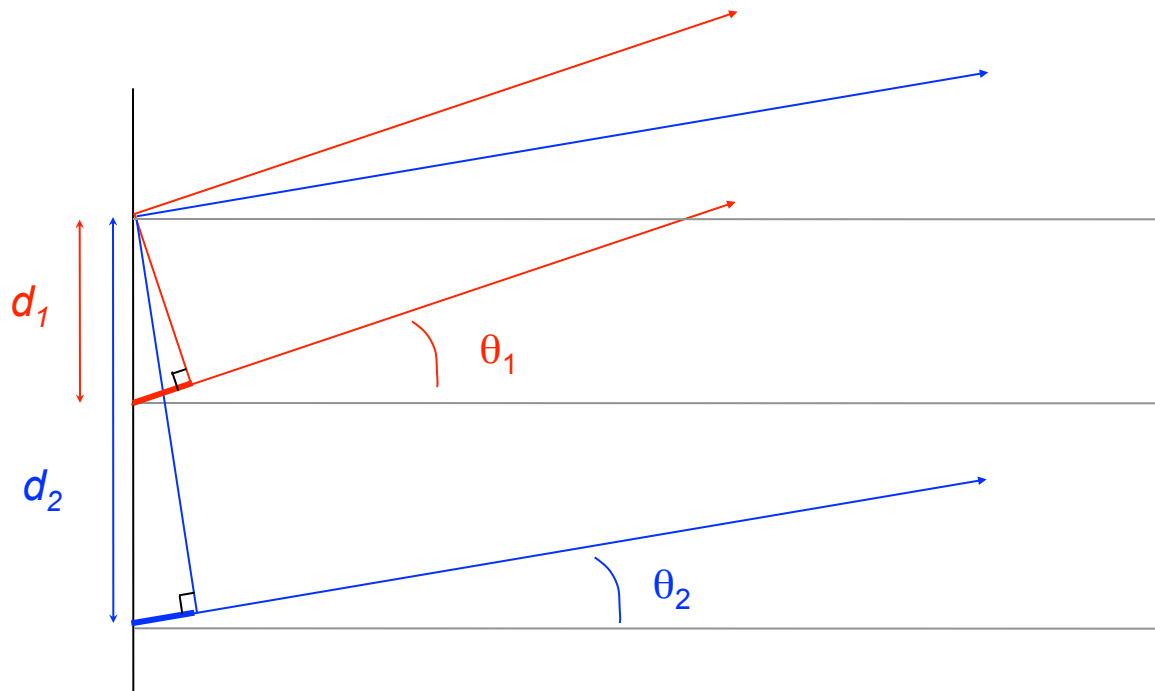

Getting the highest resolution image depends on capturing the largest angle of scattered light

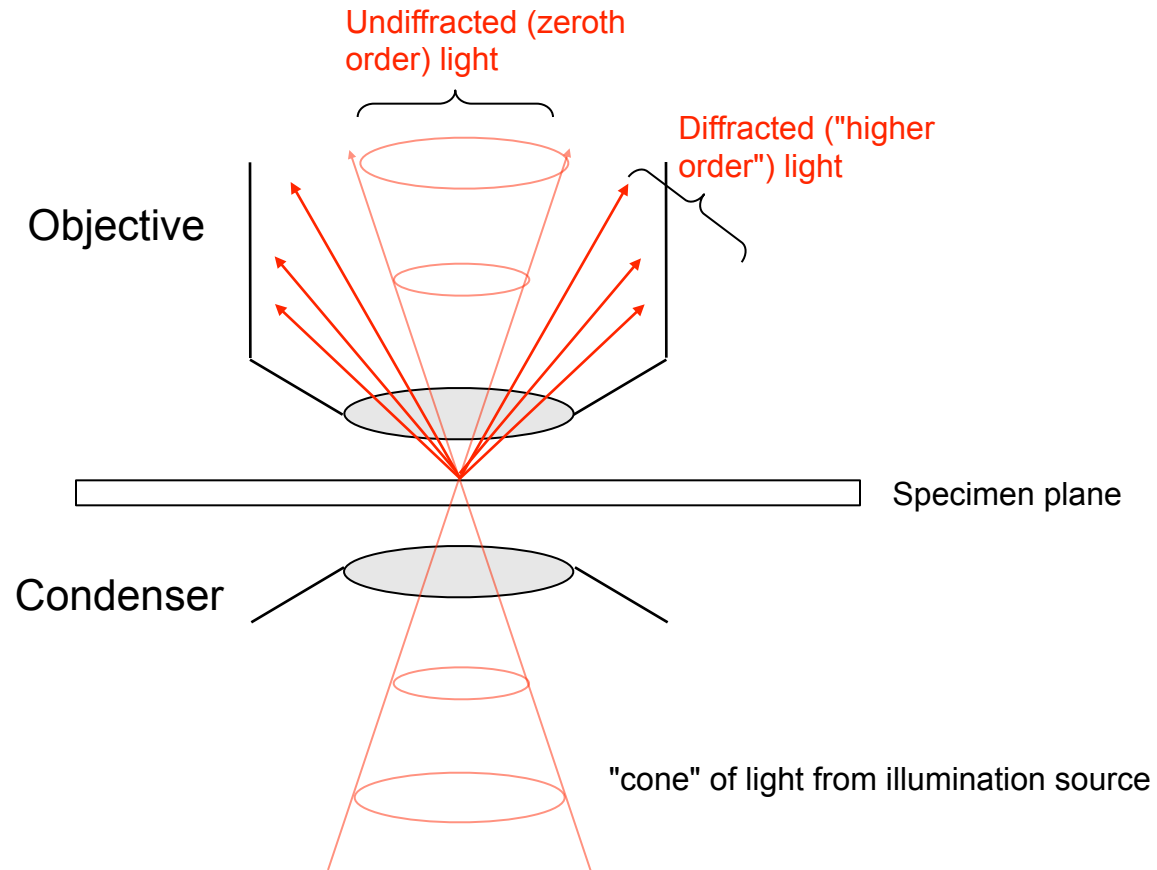

Removing higher-orders of the diffraction pattern reduces the resolution of the resulting image

- A mask is included at the diffraction plane to allow only the zeroth order and lower-order light to pass through

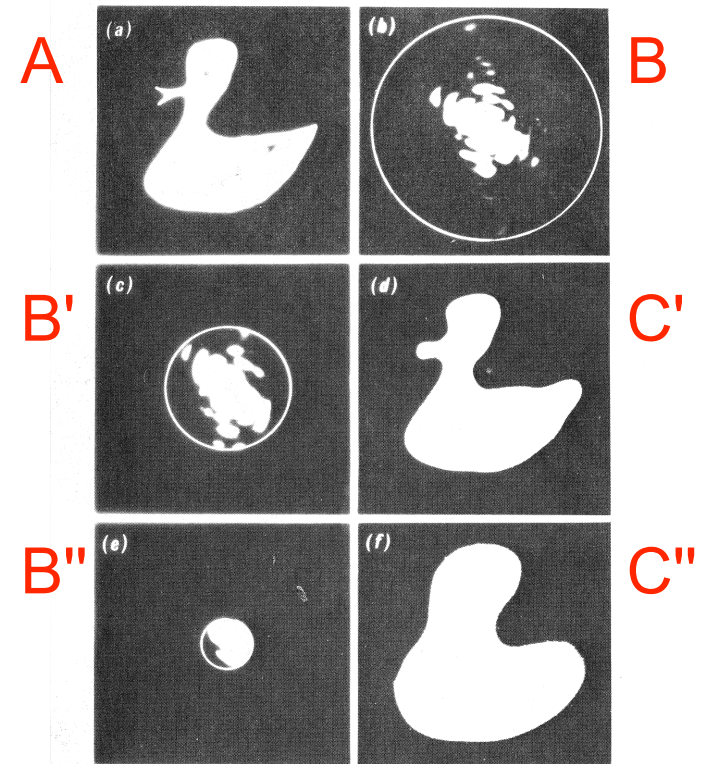
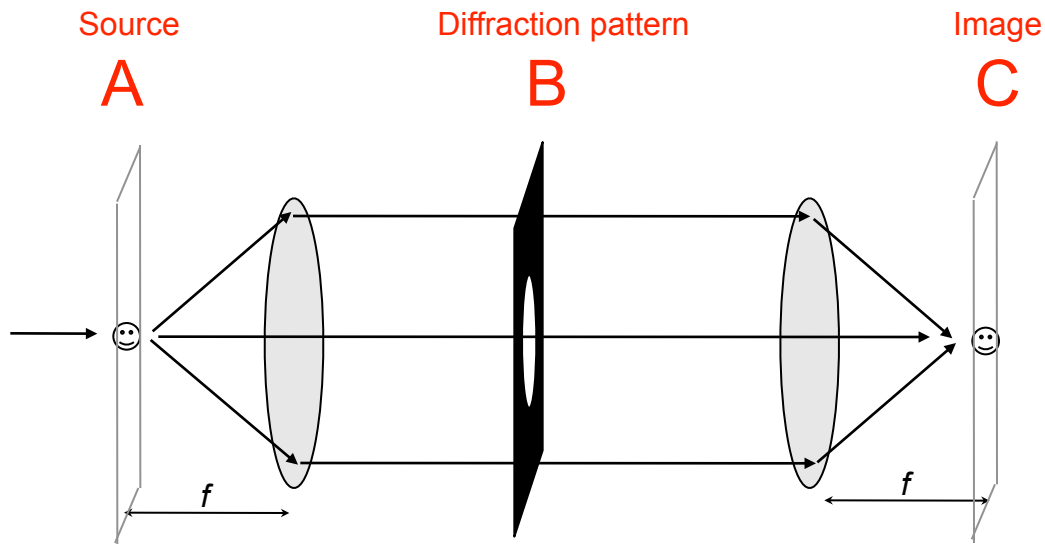
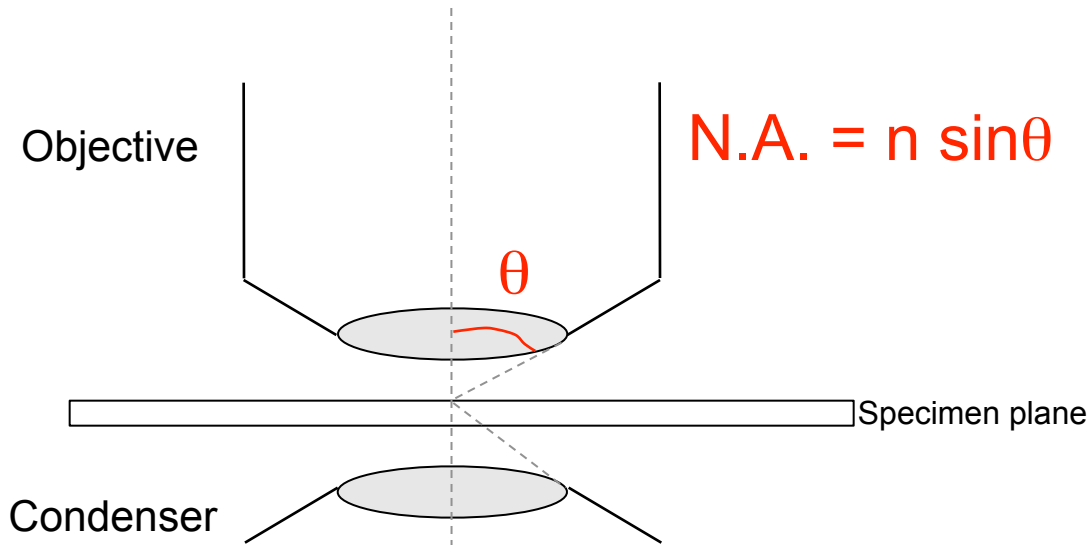

Fig. 3. The effect of taking only low angle diffraction to form the image of an object. A drawing of a duck is shown, together with its diffraction pattern. Also shown are the images formed (as the diffraction pattern of the diffraction pattern) when stops are used to cut out progressively more of the high angle diffraction pattern. [We are grateful to Dr. C. A. Taylor and Professor H. Lipson for permission to reproduce this diagram (170).]

Numerical aperture (N.A.) and wavelength determine resolution

Resolution--the ability to distinguish two point sources of light--is typically 250-300 nm, depending on wavelength, etc.



$$\text{resolution} = 0.61\lambda / N.A.$$

$$\text{More correctly, } N.A. \text{ of system} = N.A._{(obj)} + N.A._{(cond)} / 2$$

Over 100 years old!

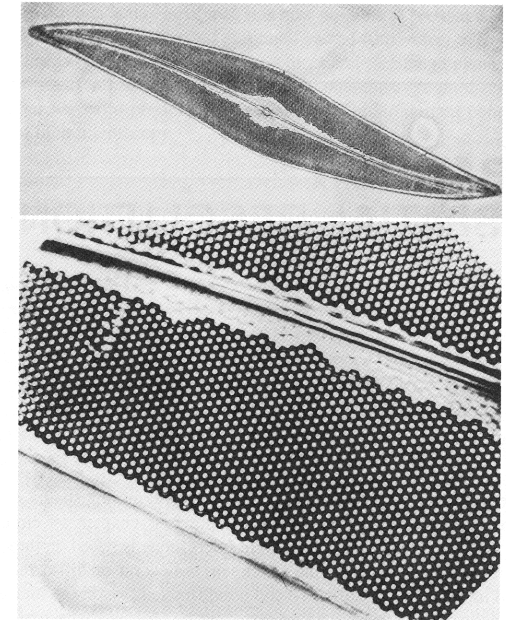

Figure 6-1

Resolution of the pores in a diatom shell with an apochromatic objective lens. Joseph Gall described these historic photographs of the diatom *Pleurosigma* prepared over 100 years ago using one of Abbe's lenses (*Molecular Biology of the Cell*, vol. 4, no. 10, 1993). "The photographs . . . are taken from a Zeiss catalog published in 1888 in which Abbe's apochromatic objectives were advertised. Both figures show the silica shell of the diatom *Pleurosigma angulatum*. Because of the regular patterns of minute holes in their shells, diatoms have long been favorite objects for testing the resolution of microscope objectives. The top figure shows an entire shell at 500 \times , a magnification beyond which many 19th-century objectives would show little additional detail. The bottom figure, reproduced here and in the original catalog at a remarkable 4900 \times , was made with an apochromatic oil immersion objective of 2.0 mm focal length and a numerical aperture of 1.3. The center-to-center spacing of the holes in the shell is 0.65 μm , and the diameter of the holes themselves is about 0.40 μm . Almost certainly this objective resolved down to its theoretical limit of 0.26 μm in green light."

N.A. and resolution

- The condenser should not be ignored when considering resolution

For highest resolution, open the condenser to fill the back focal plane

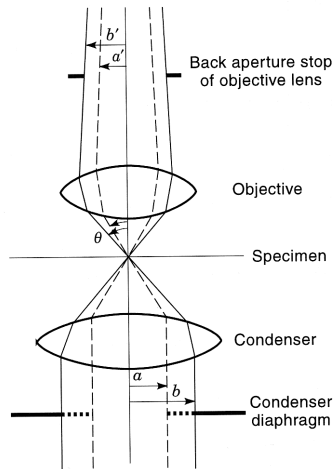

Figure 6-4

Role of the condenser diaphragm in determining the effective numerical aperture. Closing the front aperture diaphragm of the condenser from position b to a limits the angle θ of the illumination cone reaching the objective, and thus the effective numerical aperture. Notice that the back aperture of the objective is no longer filled at the reduced setting.

Condenser open

Condenser closed

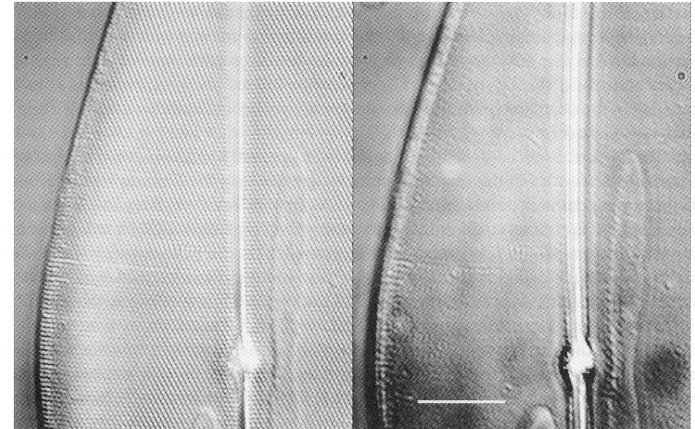

Figure 6-5

Effect of numerical aperture on spatial resolution. The diatom *Pleurosigma* photographed with a 25 \times , 0.8 NA oil immersion lens using DIC optics. (a) Condenser aperture open, showing the near hexagonal pattern of pores. (b) The same object with the condenser diaphragm closed. The 1st-order diffracted rays from the pores are not captured by the objective with a narrow cone of illumination. Spatial resolution is reduced, and the pores are not resolved. Bar = 10 μm .

Different types of condensers

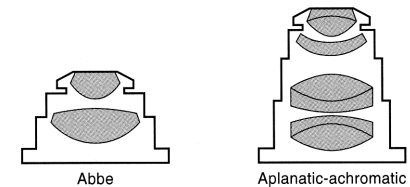
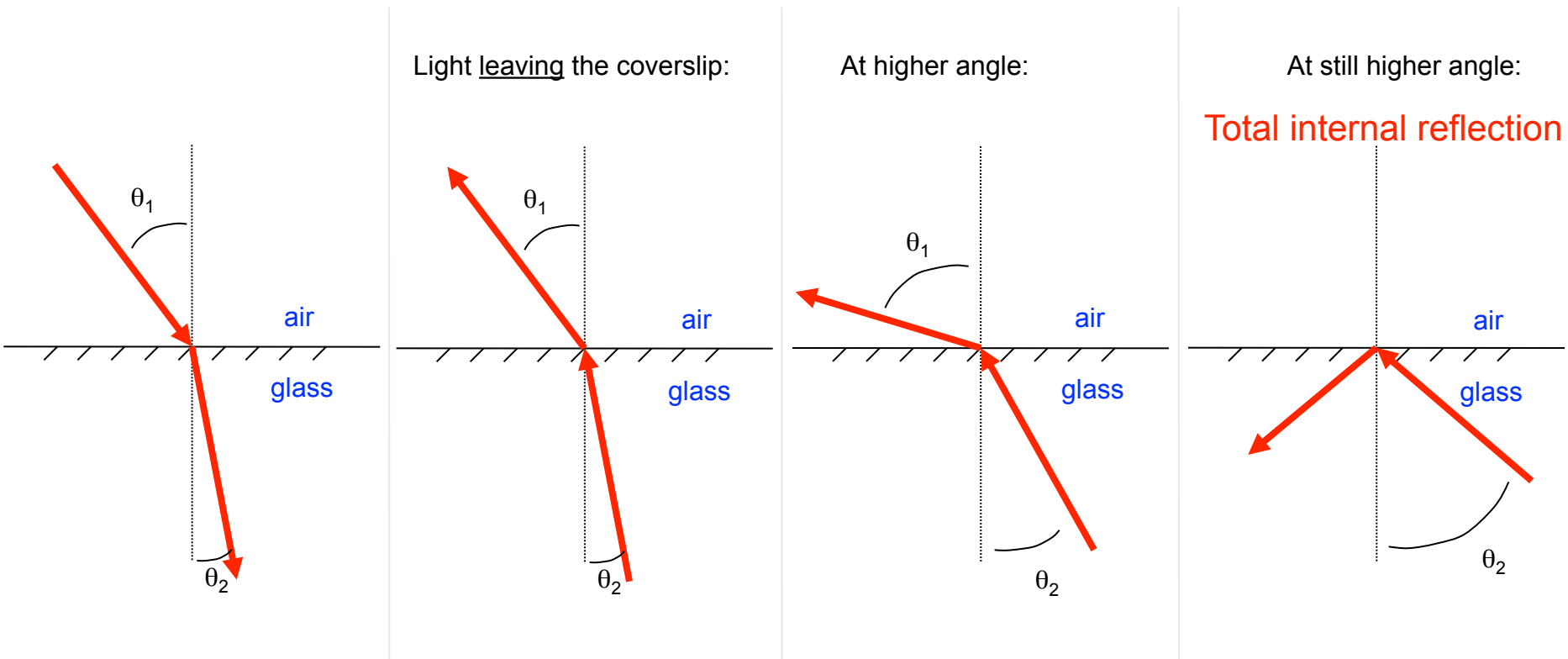

Figure 4-11

Two common microscope condensers. The Abbe condenser contains two achromatic doublet lenses and gives very good performance for dry lenses of low to medium power. The achromatic-aplanatic condenser is useful for lenses with $\text{NA} > 0.5$, and is essential for oil immersion lenses with high numerical apertures. For low NA performance, the top element of this condenser can be removed. This condenser focuses light in a flat focal plane and is highly corrected for the significant lens aberrations.

Why we use immersion oil with high-power objectives

- In fact, immersion oil can also be used with relatively low power objectives (e.g. 25X).
- But with high power objectives, magnification without resolution is useless, so the N.A. must be maximized
- Refraction of light leaving the specimen, passing through a coverslip, and reaching the coverlip-air interface is the problem--total internal reflection



Why we use immersion oil with high-power objectives

- In fact, immersion oil can also be used with relatively low power objectives (e.g. 25X).
- But with high power objectives, magnification without resolution is useless, so the N.A. must be maximised
- Refraction of light leaving the specimen, passing through a coverslip, and reaching the coverslip-air interface is the problem--total internal reflection

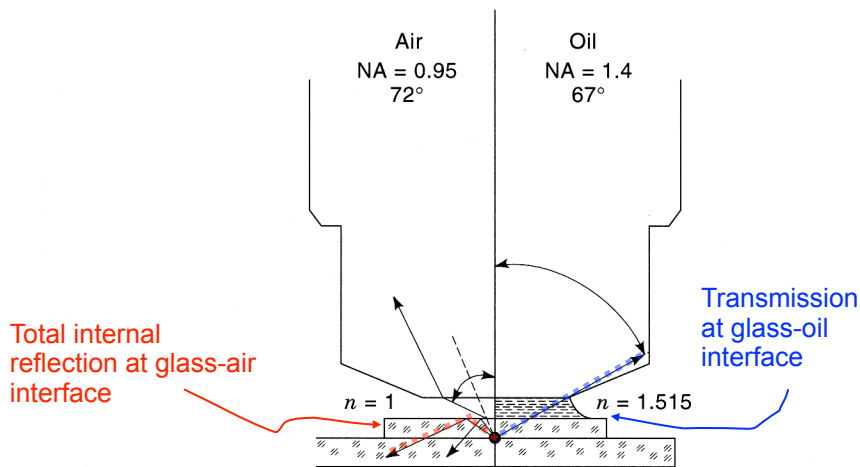

Figure 6-2

Effect of immersion oil on increasing the angular extent over which diffracted rays can be accepted by an objective lens. Numerical aperture is directly dependent on the wavelength λ and the sine of the half angle of the cone of illumination θ accepted by the front lens of the objective. For dry lenses, NA is limited, because rays subtending angles of 41° or greater are lost by total internal reflection and never enter the lens (dotted line). The practical limit for a dry lens is $\sim 39^\circ$, which corresponds to an acceptance angle of 72° , and an NA of 0.95. By adding high-refractive index immersion oil matching that of the glass coverslip ($n = 1.515$), an oil immersion objective can collect light diffracted up to 67° , which corresponds to NA = 1.4.

•The "standard" coverslips are "thickness 1.5", which are 0.16-0.19 mm thick

•"thickness 1" coverslips are quite thin, and tend to break easily--don't buy them!

•Changing coverslips or refractive index of immersion oil can help for very high-resolution or special-purpose imaging

Reading objective markings--a field guide

- All modern microscopes for the last ~15 years (Zeiss, Nikon, Olympus, Leica) use "infinity-corrected" optics rather than standard 160 mm tubelength optics (RMS standard). Older and/or cheaper scopes may still use the RMS standard
- With old (RMS) standard, objectives were completely interchangeable
- With new standards, companies have gone their separate ways, and the optics can be fundamentally different (and threads are often not compatible anyhow).

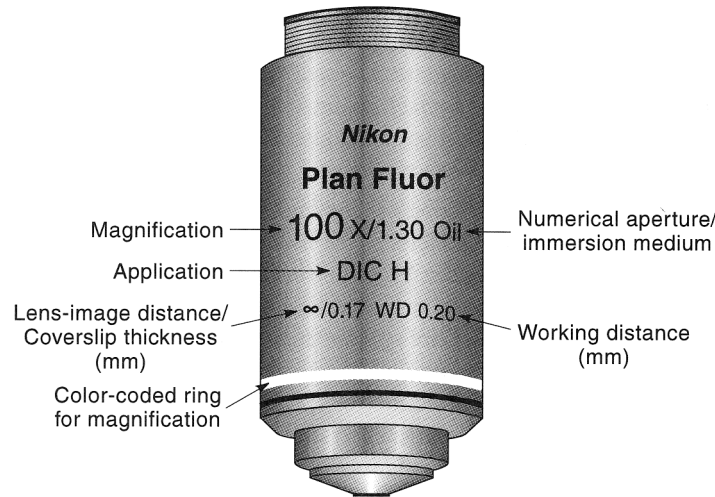

Mag.	1X	2X	4X	10X	20X	40X	50X	60X	100X
Color code	Black	Gray	Red	Yellow	Green	Light blue	Light blue	Dark blue	White

Figure 4-10

Key for interpreting the markings on the barrel of an objective lens. Markings on the lens barrel indicate the type of lens and correction, initial magnification, immersion medium, numerical aperture, lens-image distance, and required coverglass thickness. For quick reference, the color-coded ring, near the thread, denotes the initial magnification, while the color-coded ring near the front lens denotes the type of immersion medium (black-immersion oil, white-water, orange-glycerin, yellow-methylene iodide, red-multi-immersion).

Key points

- Basic understanding of refraction and diffraction, and properties of lenses
- Understanding of two different sets of conjugate planes, especially importance of objective back-focal plane
- Understanding of factors affecting image resolution

References

- J. B Sanderson, Understanding Light Microscopy - RMS - Royal Microscopical Society
- D.B. Murphy, Fundamentals of Light Microscopy and Electronic Imaging
- E. Hecht, Optics
- www.micron.ox.ac.uk