

CAMERA SENSORS FOR MICROSCOPY

Matt Preston

What do we want a sensor to do?

- Take a image – full marks have a medal....
- Quickly / As fast as we can
- From many different light levels
- With good dynamic range
- From signals of differing emission wavelengths
- With enough resolution to see detail
- With limited noise

Sensitivity

- Sensitivity is a horrible word which is often confused with Quantum Efficiency, Pixel Size, Signal and Signal to Noise.

We do know some key facts:

- Photons convert to electrons in sensors and they can then be measured – this conversion rate is defined as Quantum Efficiency
- Sensors convert photons of some wavelengths better than others
- The number of photons that interact with our pixel will depend on the physical size of the pixel
- We can have a sensitive sensor but if our signal to noise is low we get a noisy image with data we cannot decipher

What is Quantum Efficiency?

- Quantum efficiency (QE) is a measure of the effectiveness of an imager to produce electronic charge from incident photons.
- In the high-purity crystalline form, each atom of silicon is covalently bonded to its neighbour. Energy greater than the band gap energy, about 1.1 eV, is required to break a bond and create an electron/hole pair.
- The wavelength of incoming light and photon absorption depth are directly related; the shorter the wavelength, the shorter the penetration depth into the silicon.
- Light normally enters the CCD through gates of the parallel register (front-illuminated CCD). These gates are made of very thin polysilicon, which is reasonably transparent at long wavelengths, but becomes opaque at wavelengths shorter than 400 nm. Thus, at short wavelengths, gate structure attenuates incoming light.

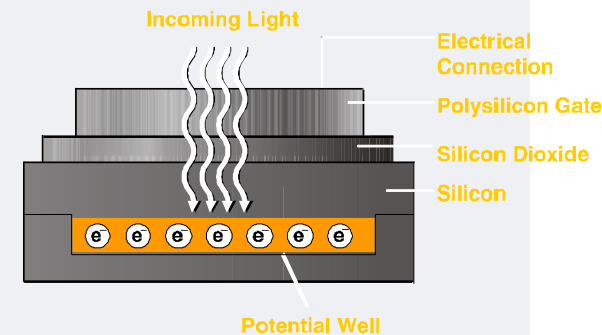

QE Curves

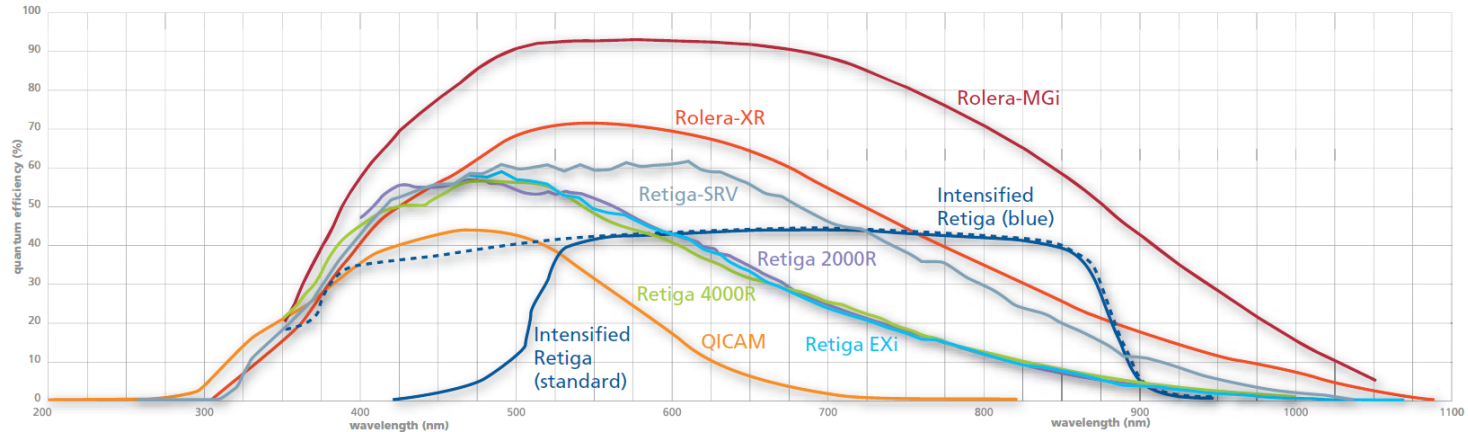

- Spectral response curves are often shown on camera specification sheets.
- Some manufacturers claim higher responses than are achievable , but note these often vary from sensor to sensor
- Some manufacturers will also quote a relative response from 0 to 1
- The battle for good QE is fought in the flatness, max peak and responses to red dyes such as Cy5 (670nm)
- A QICAM is not suitable at this part of the spectrum as QE is only 5% at 670nm

Front and Back illumination

- Some cameras are back thinned and back illuminated to be as efficient as possible with incoming light
- Typical front illuminated QE 40-60% at Lambda Max
- Typical Back illuminated QE 90% at Lambda Max

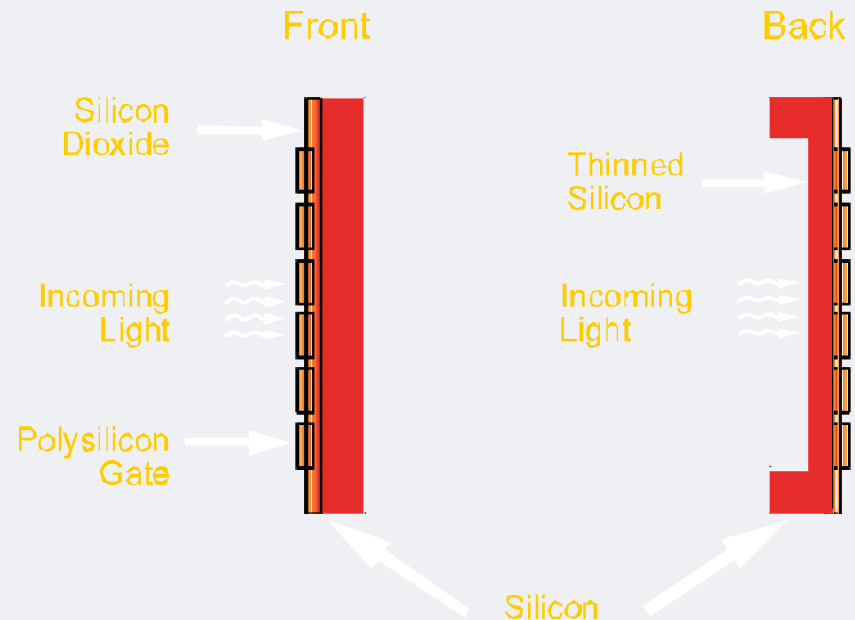

What is actually happening at each Pixel?

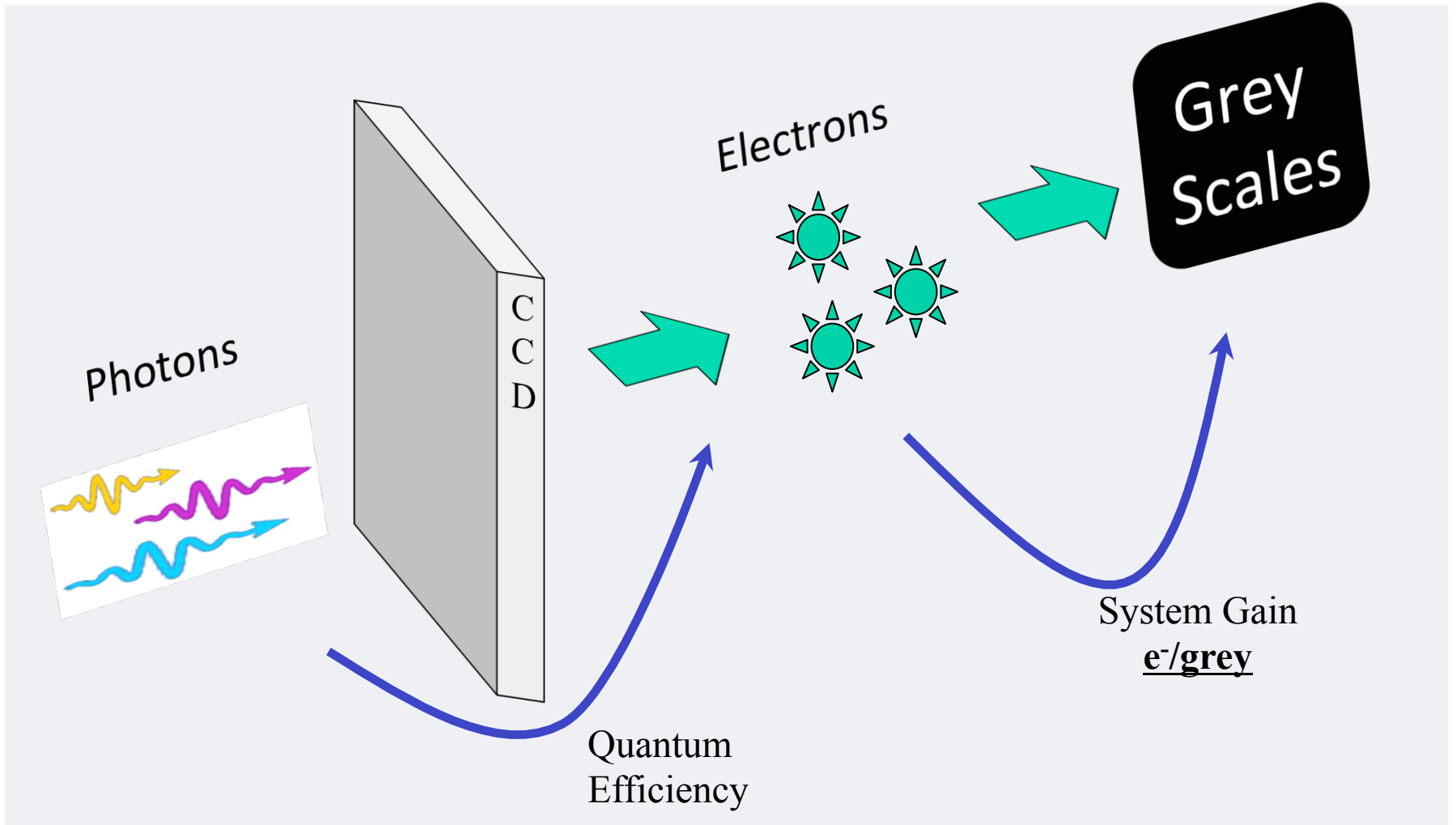

What's happening

1. Photon hits the CCD sensor
2. Photon is then converted to an Electron
3. Electron is then digitised using an Analogue to Digital converter (ADC)
4. Electron value is now converted to a grey scale
5. User measures grey scale (ADU)

Note - The camera is completely in control over grey scale values and changing camera parameters doesn't change the light detected.

Sensors – What are our main types

- CCD – Charged Coupled Device
- EMCCD – Electron Multiplied CCD
- CMOS – Complementary Metal Oxide Semiconductor

CCD Fundamentals

The Charge-Coupled Device

- Invented in 1970 at Bell Labs
- A silicon chip that converts an image to an electrical signal
- Image is focused directly onto the silicon chip
- Widely used in TV cameras and consumer camcorders
- Special high-performance CCDs made by:
 - Eastman Kodak (Rochester, NY)
 - Thomson CSF (France)
 - Marconi (formerly EEV — England)
 - SITe (Beaverton, OR)
 - Sony
 - Others

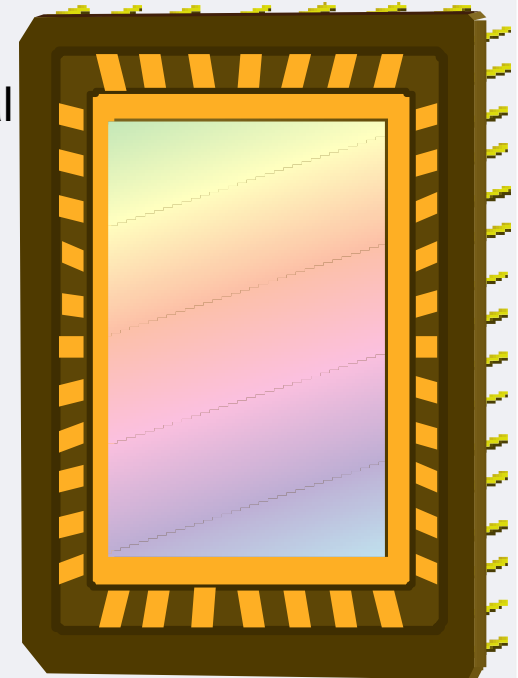

CCD Fundamentals

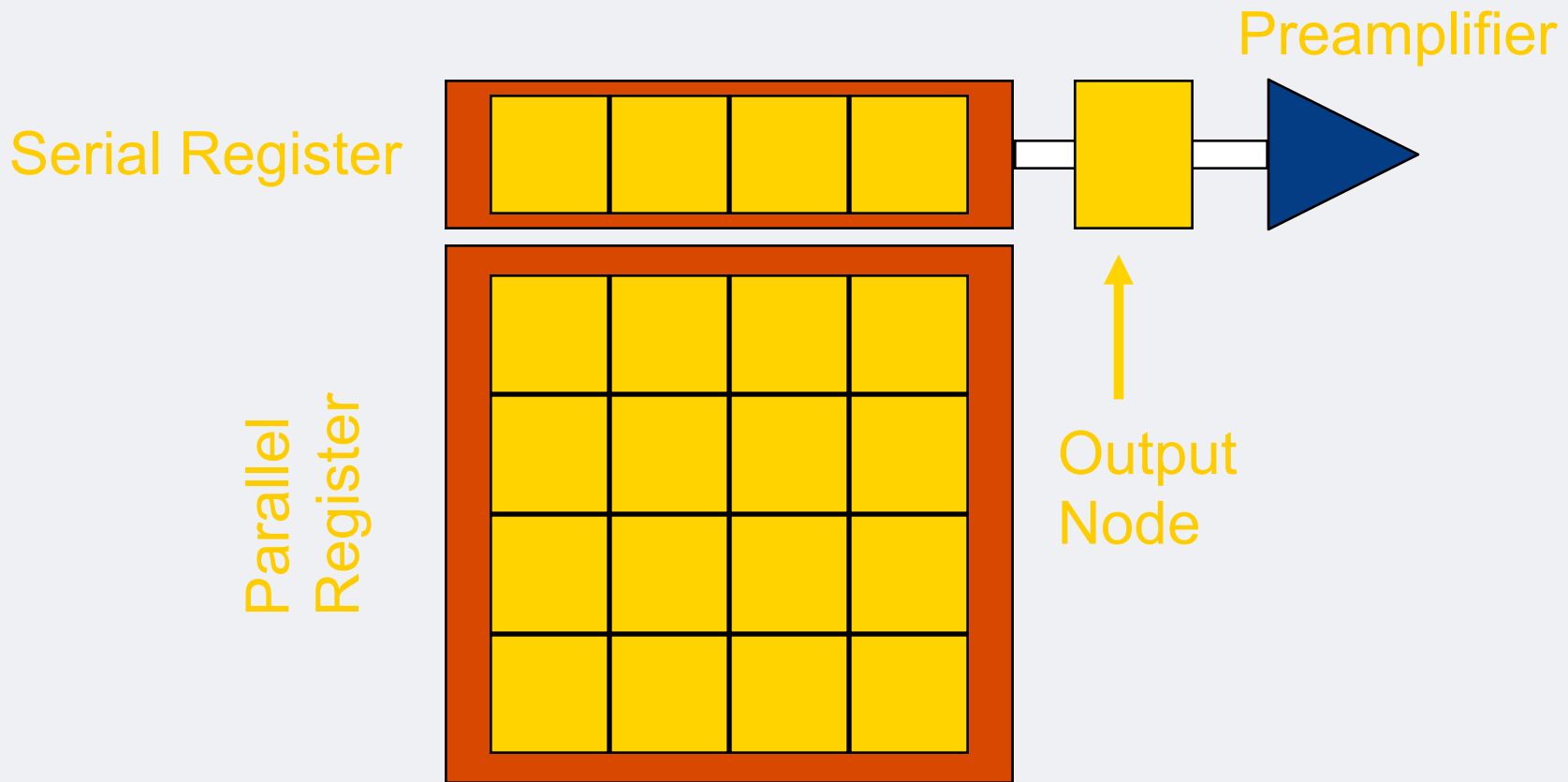

CCD Fundamentals

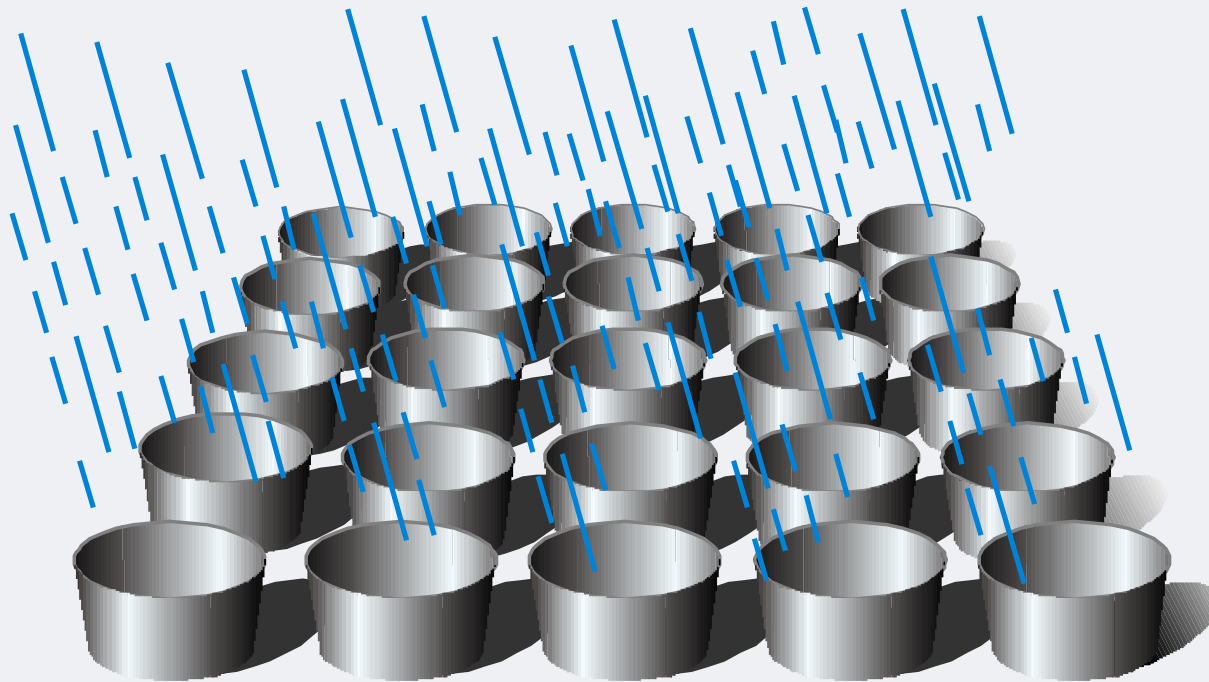

Array of Discrete Photodetectors

CCD Fundamentals

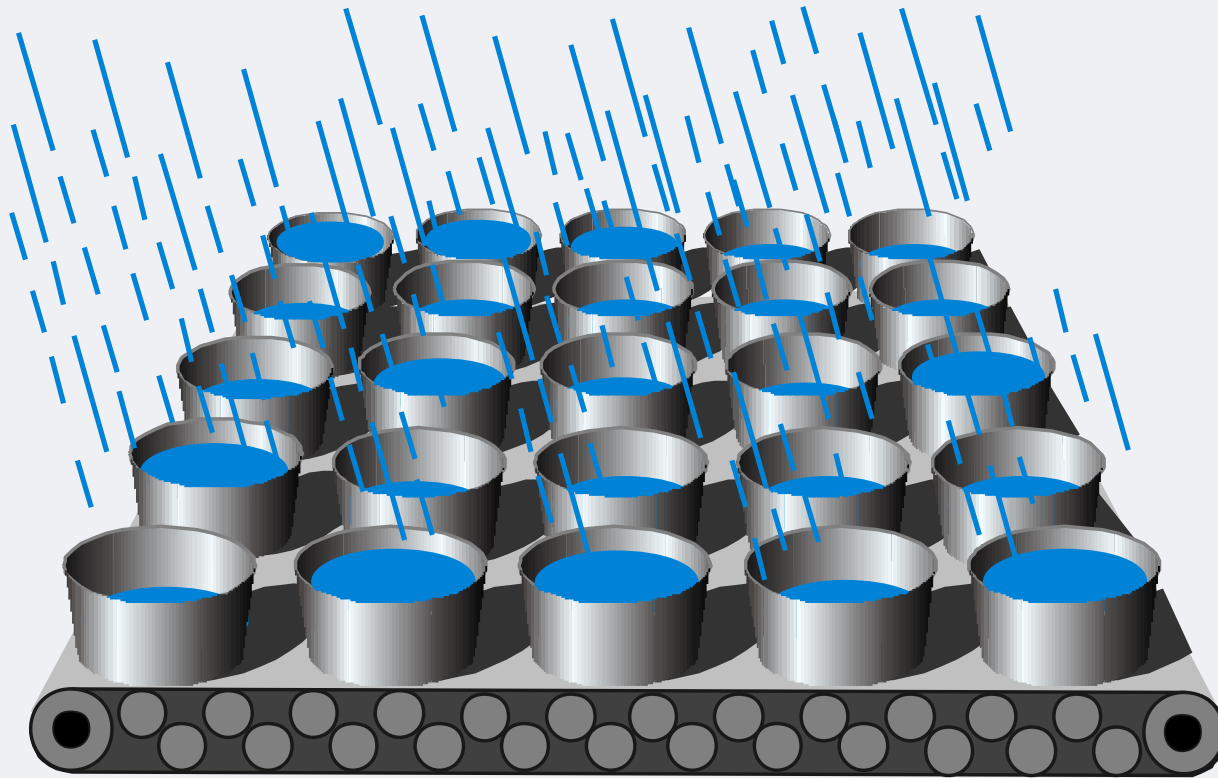

CCD Operation
Integration of Photo-Induced Charge

CCD Fundamentals

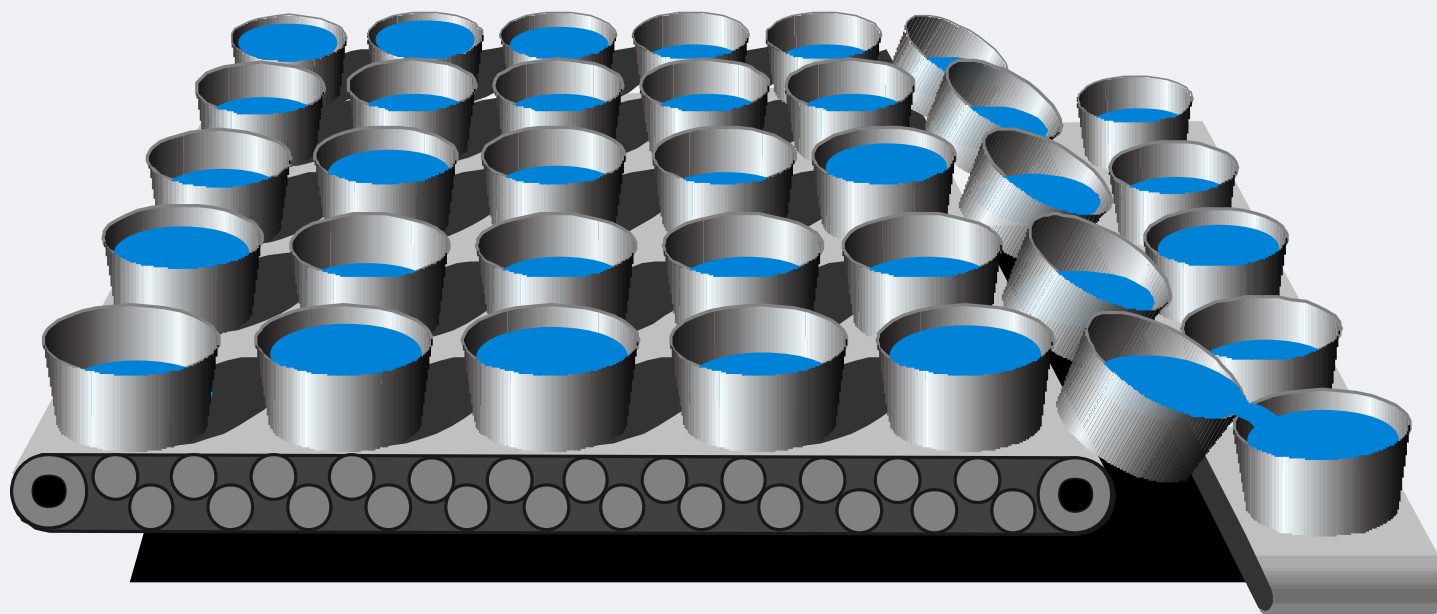

*CCD Operation
Parallel Shift - 1 Row*

CCD Fundamentals

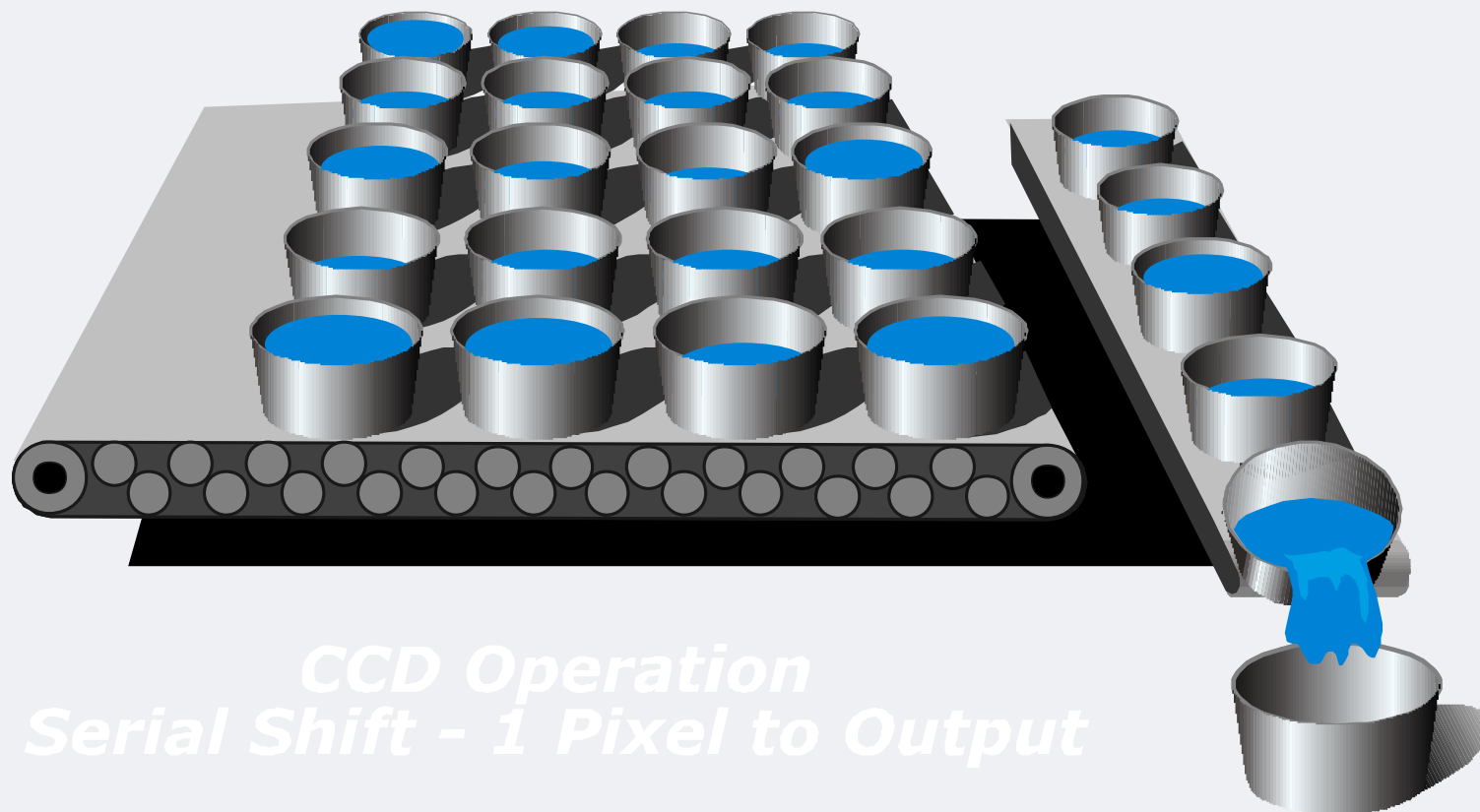

CCD Fundamentals

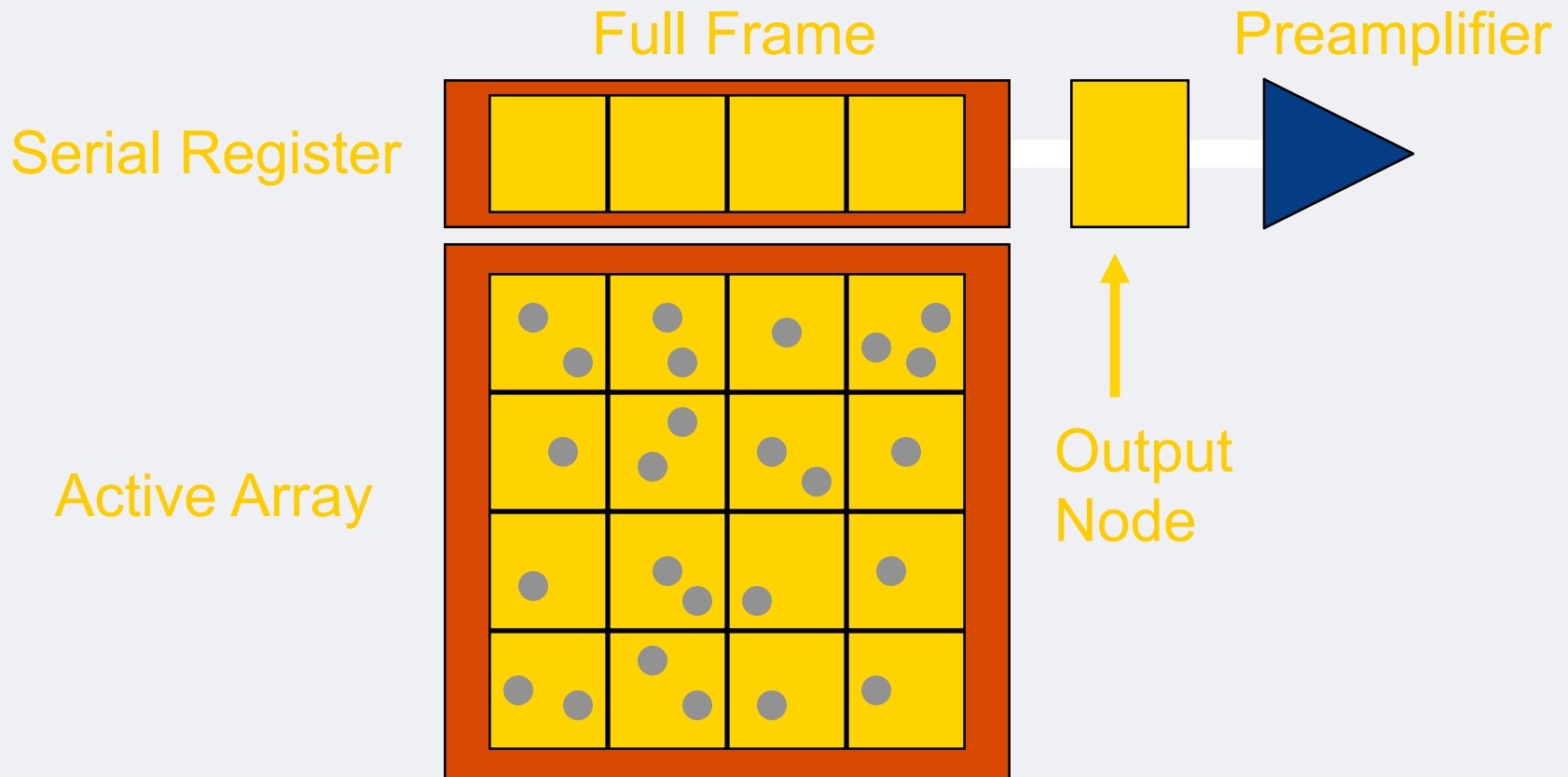

CCD Fundamentals

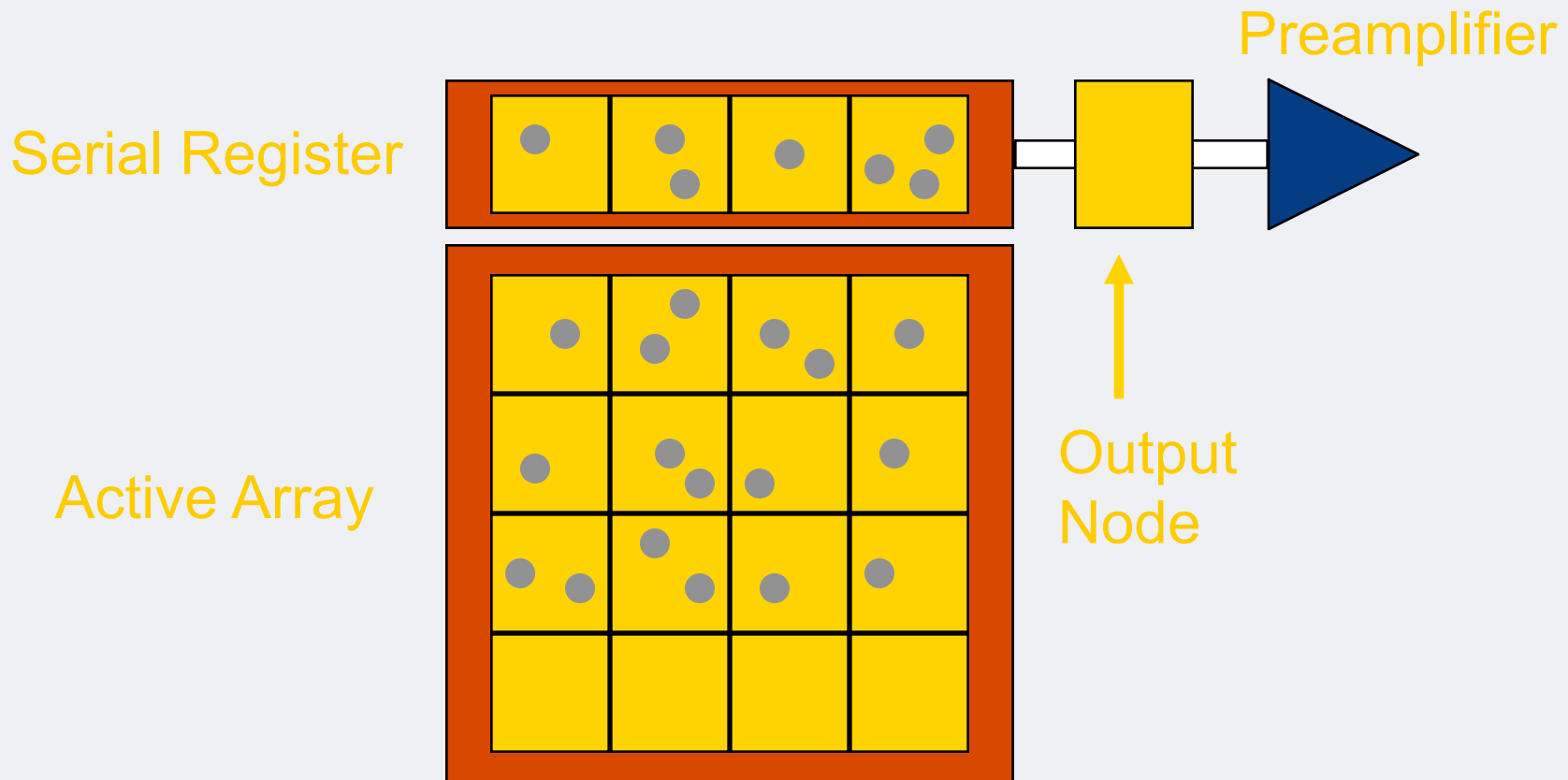

CCD Fundamentals

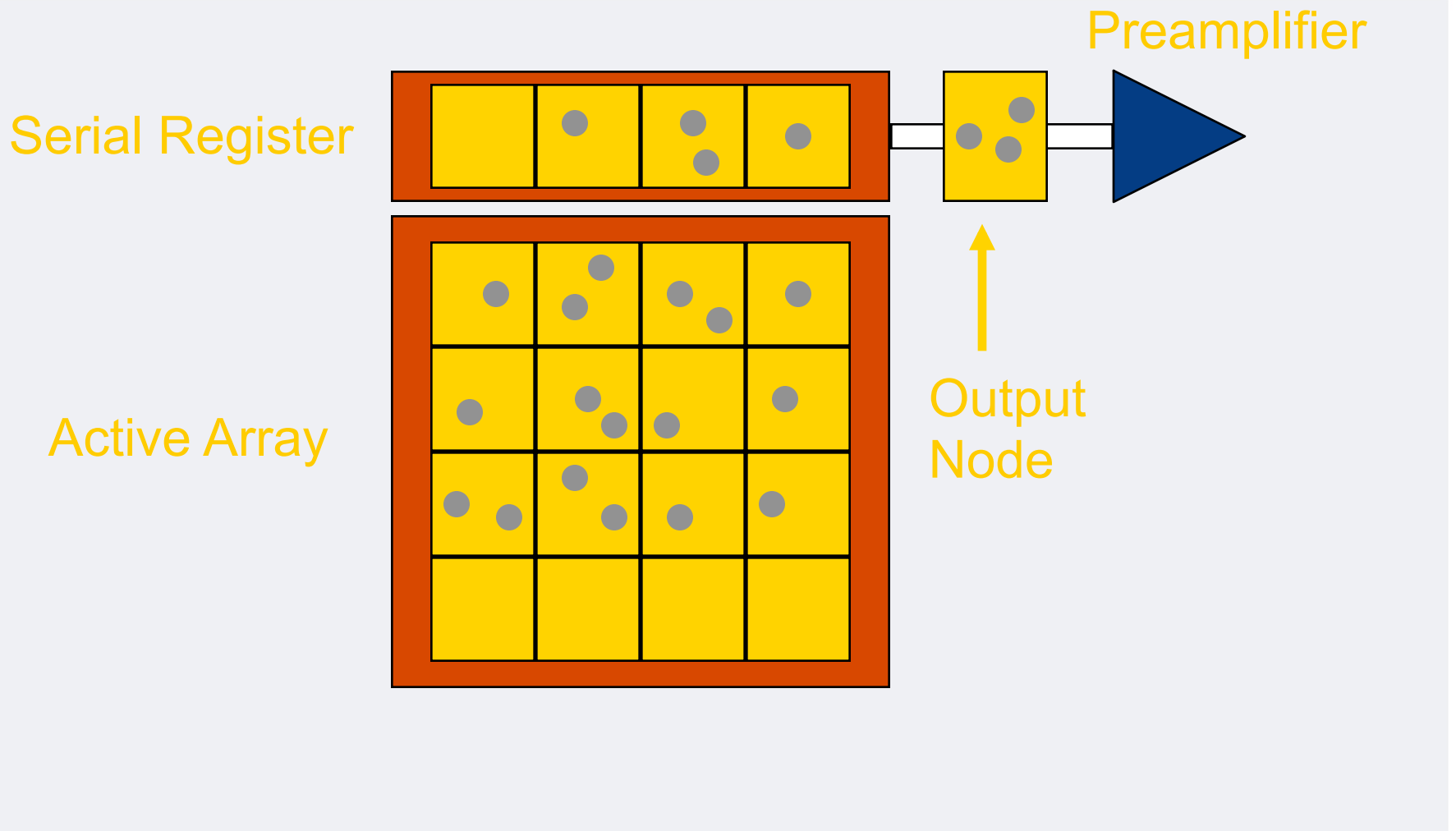

CCD Fundamentals

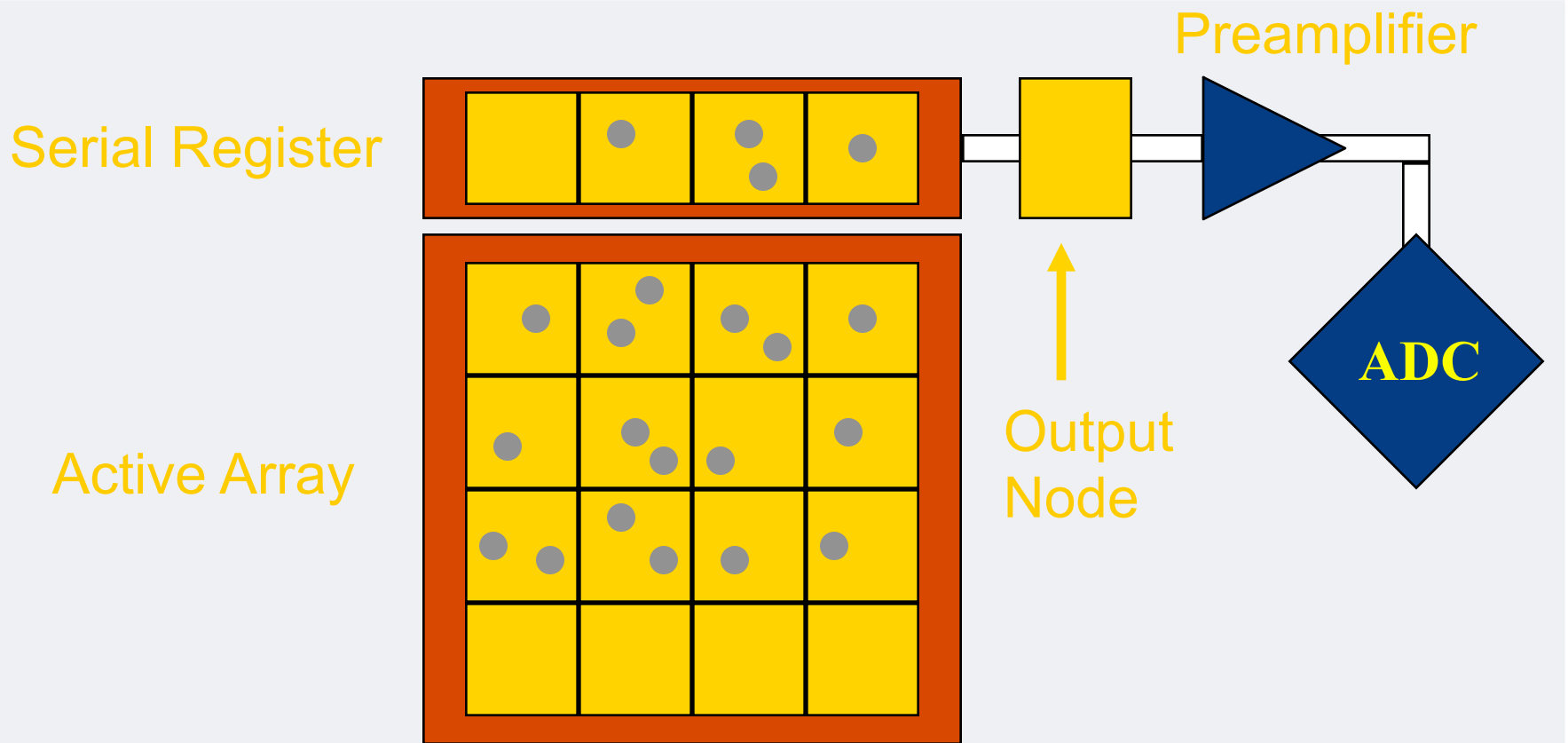

CCD Fundamentals

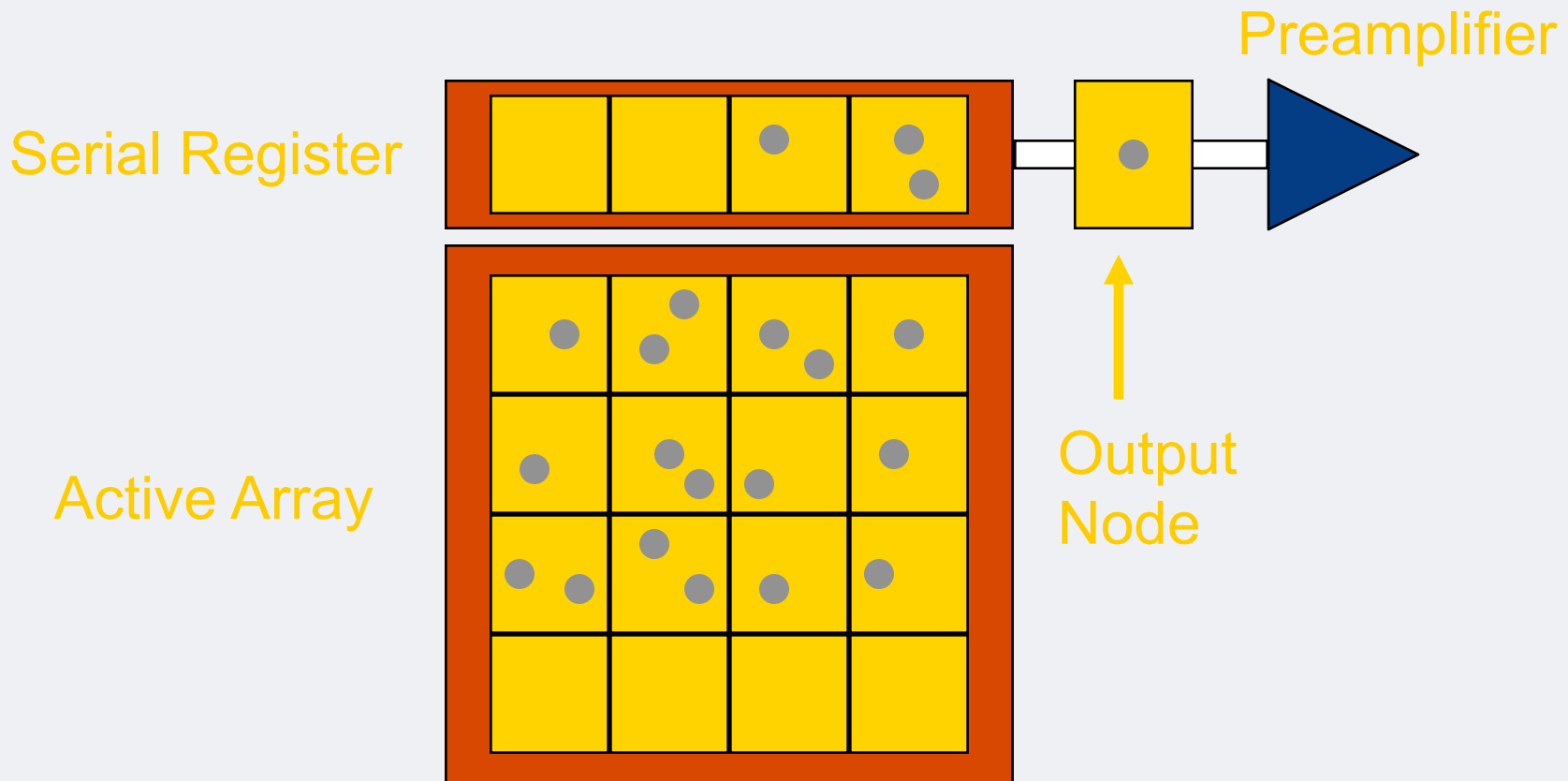

CCD Fundamentals

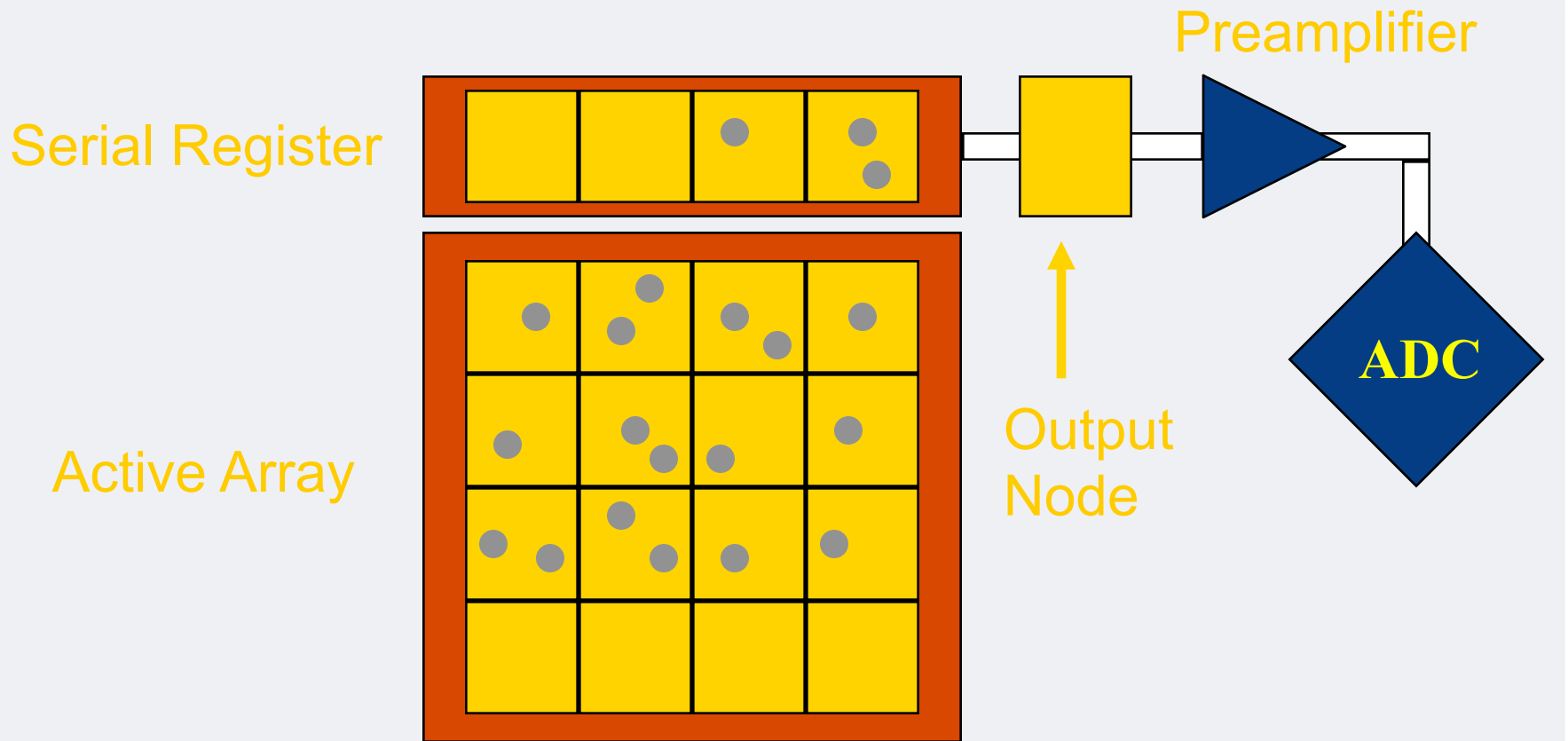

CCD Fundamentals

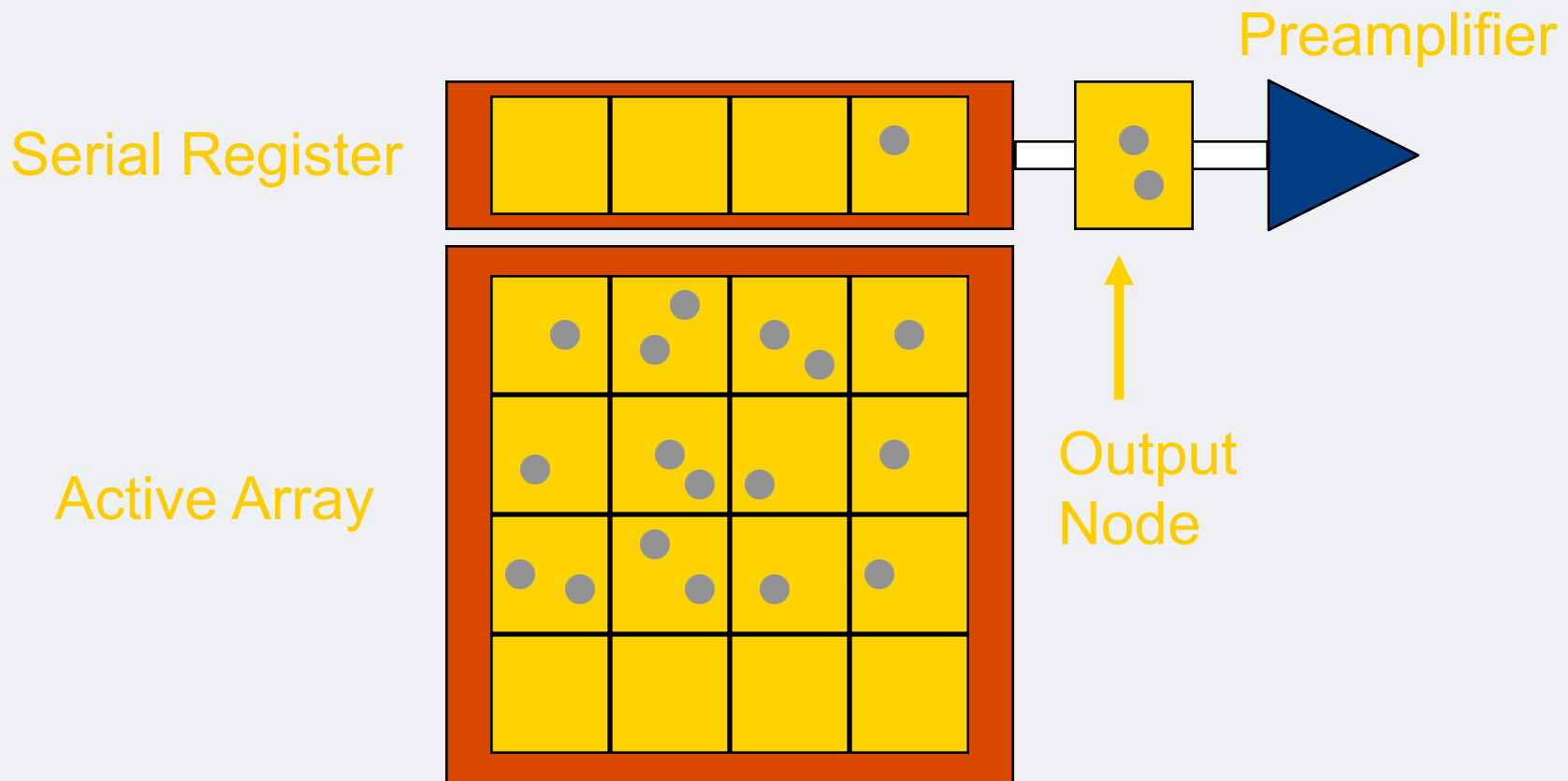

CCD Fundamentals

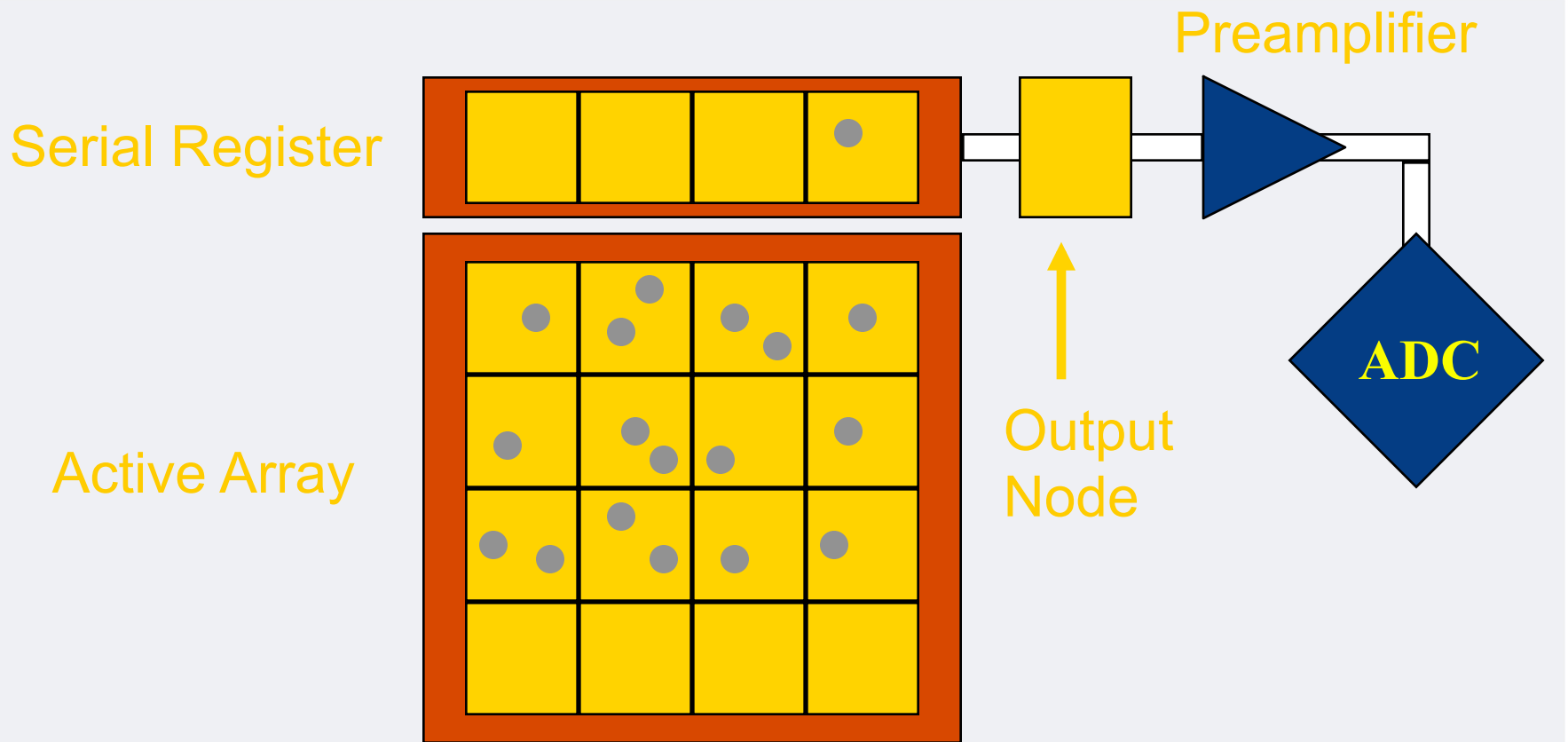

CCD Fundamentals

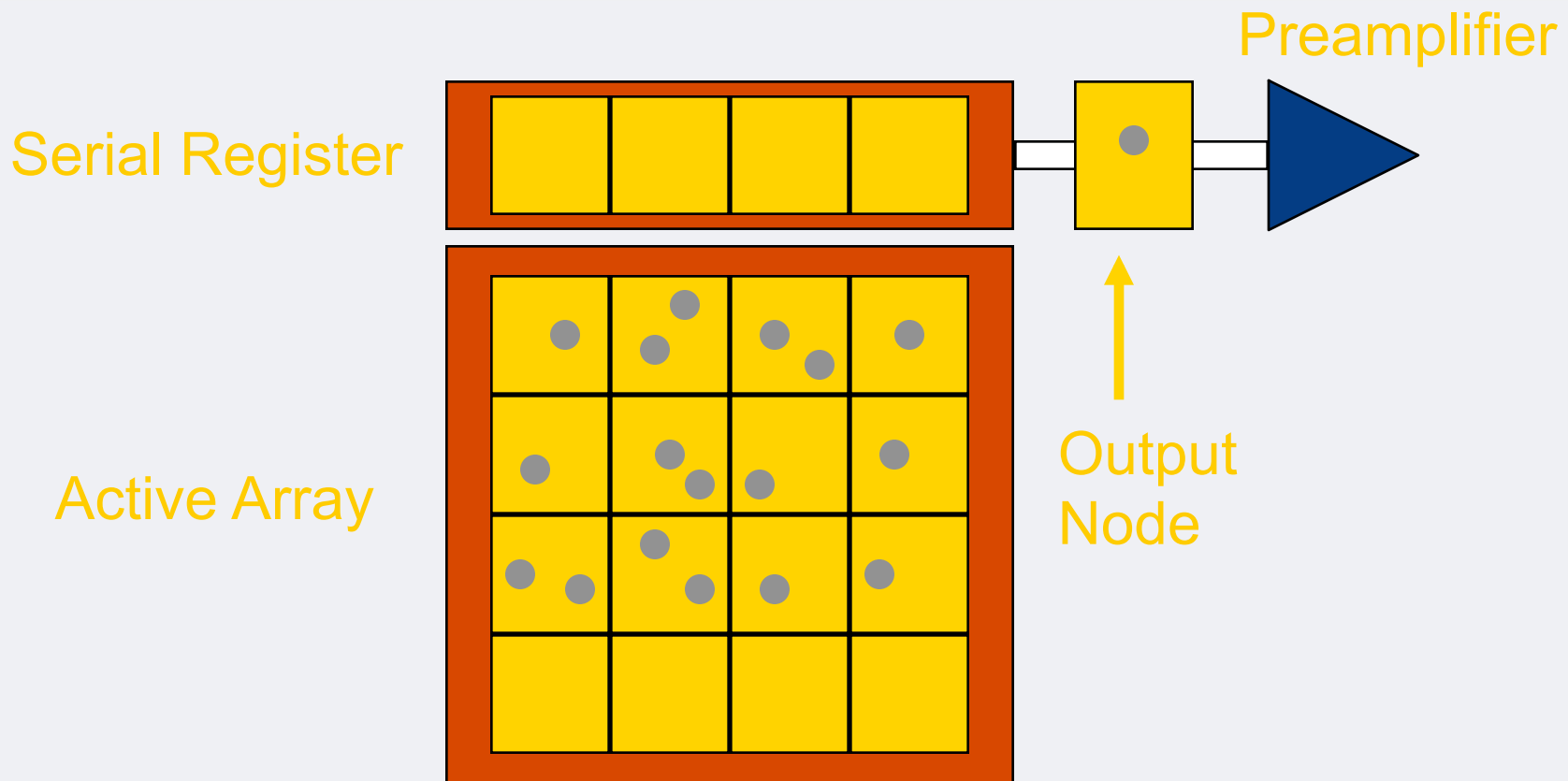

CCD Fundamentals

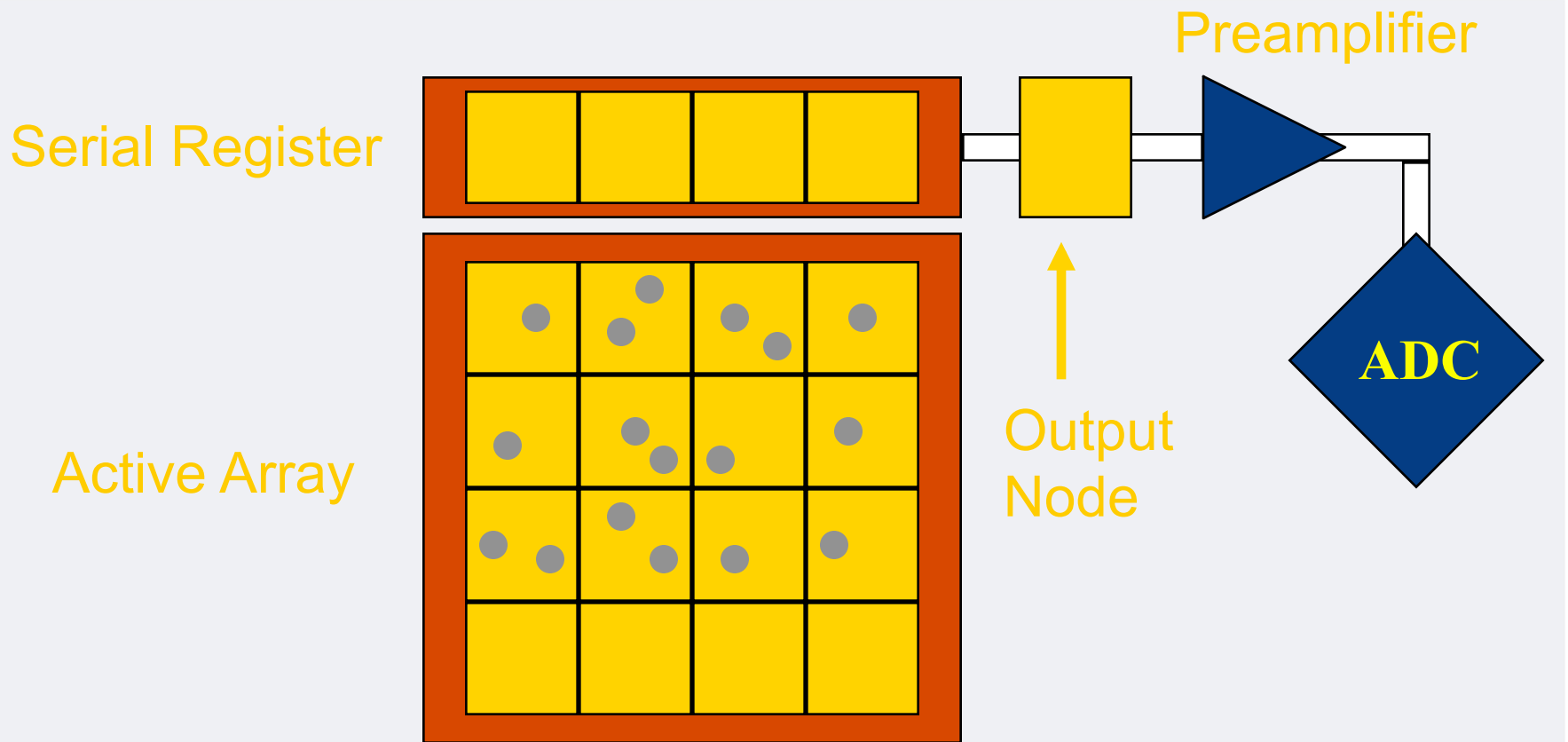

CCD Fundamentals

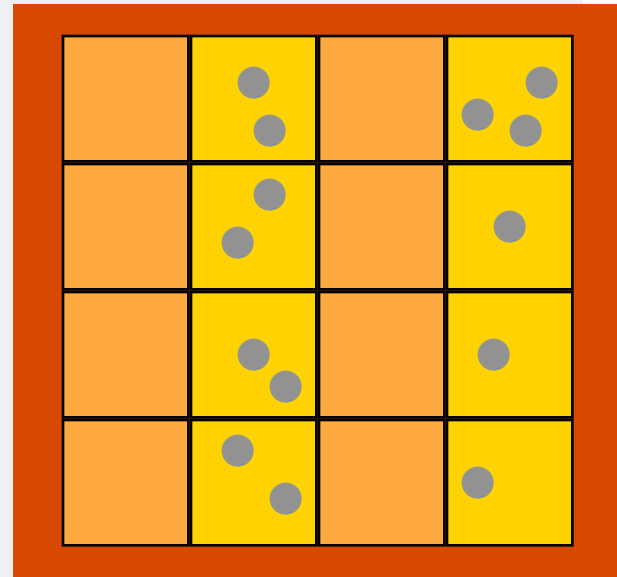
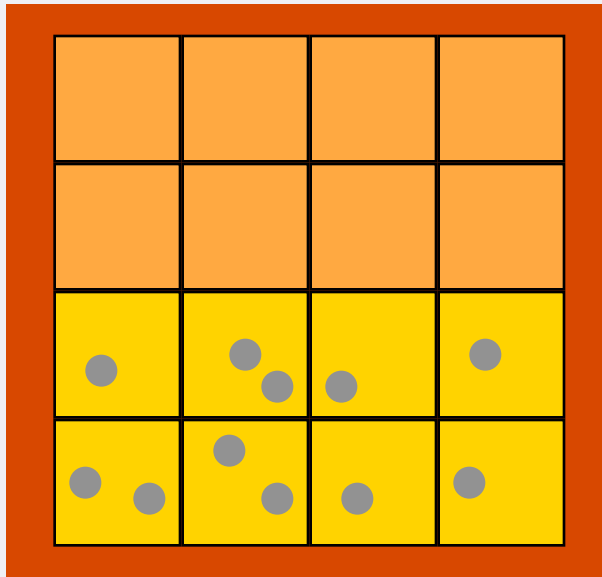
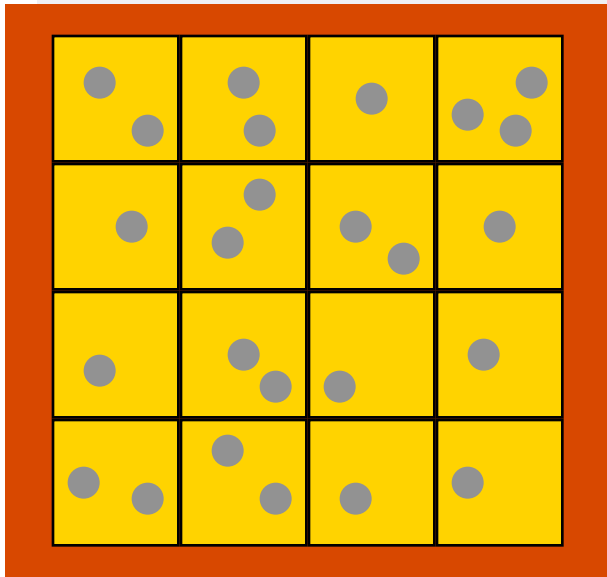
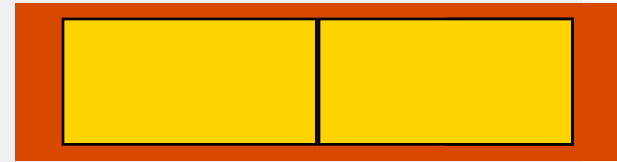
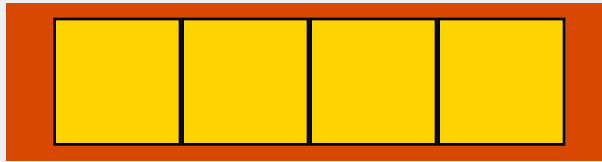
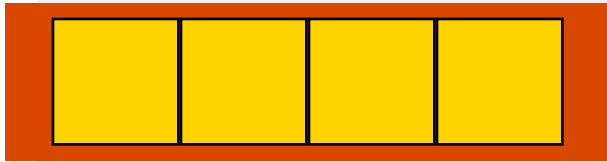

Full Frame

Frame Transfer
(EMCCD)

Interline Transfer

Before EMCCD and SCMOS

Lets look at camera noise

What is Noise ?

- Noise is uncertainty
 - Noise is Plus or Minus
 - Noise is driven by Statistics
 - Noise can be calculated
- Noise is not background

Standard Deviation is an easy way for us to measure noise.

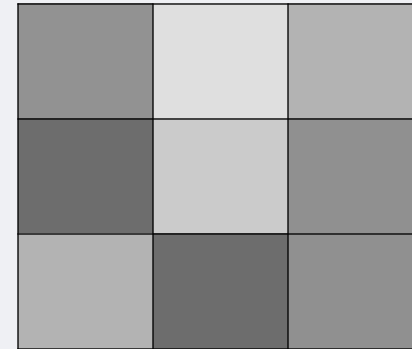

8	12	6
6	10	8
10	6	8

Living with Noise

Noise exists on every camera and in every measurement

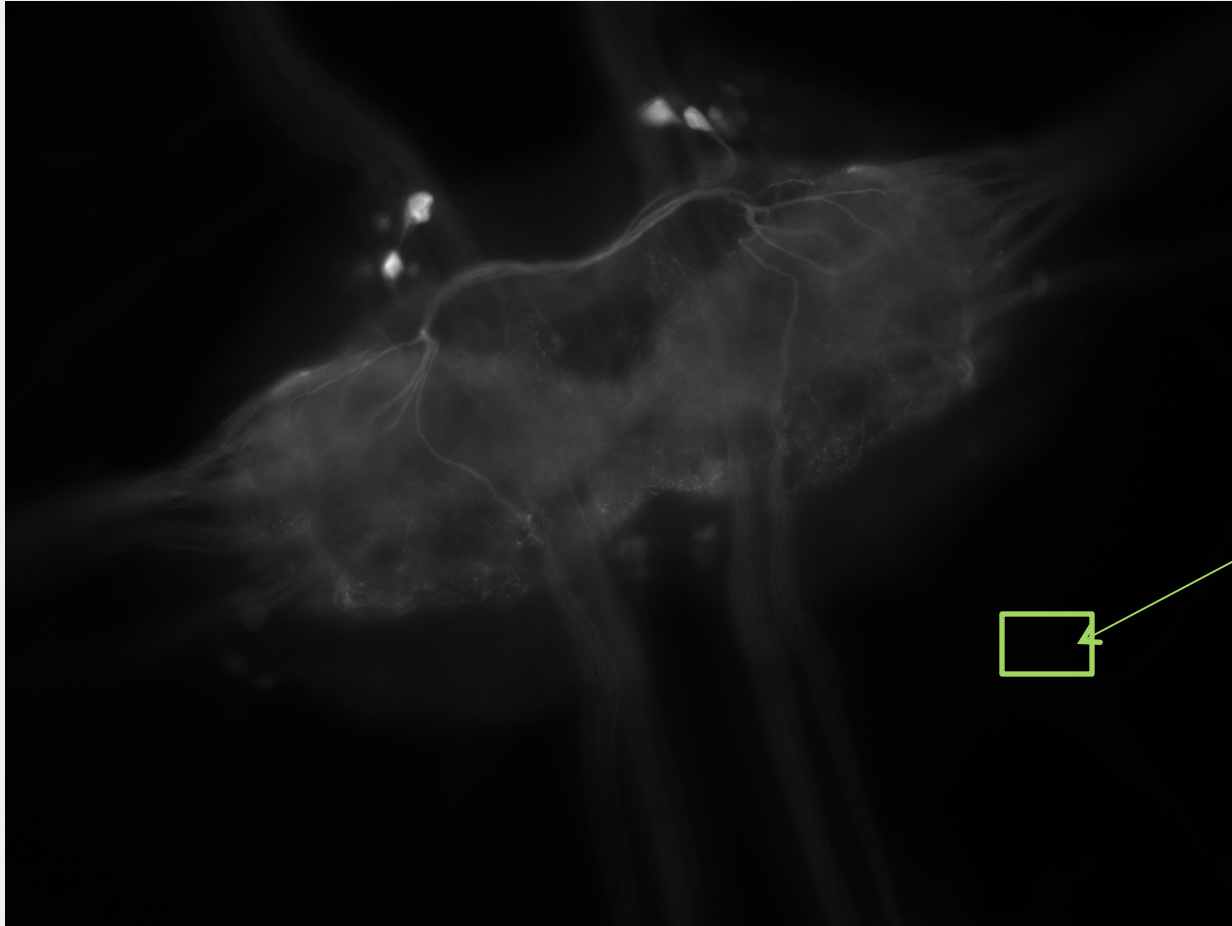

Dependent on the image scale used you may or may not see it.

Why do we see noise ?

- We normally see noise when the signal we have is low in comparison to our required exposure

Reasons for trying to get a short exposure:

- Need to monitor at high speed
- Need to minimise sample damage
- Need to focus at live rate

- If you measure a signal of 100 electrons in one pixel and 102 in another, are they different values?

- Noise distorts measurements and increases the uncertainty in measurements.

Noise Sources

CCD systems suffer from 3 types of noise:

1. **Dark Current** – noise from heat and cosmic noise - exposure dependent
2. **Read Noise** – noise of reading the signal - fixed
3. **Photon Shot** – square root of signal - signal dependent

Other Noises

1. Excess Noise Factor – EMCCD
2. Clock Induced Charge – All but mainly observed in EMCCD
3. Random Telegraph Noise - CMOS

Read Noise

- Minimized by careful electronic design
- Under low-light/low-signal conditions where read noise exceeds photon noise, data is read noise limited
- Read noise is not as significant in high-signal applications
- Read noise = $\text{std}^* \text{system gain}^* 0.707$
(std of subtracted bias images)

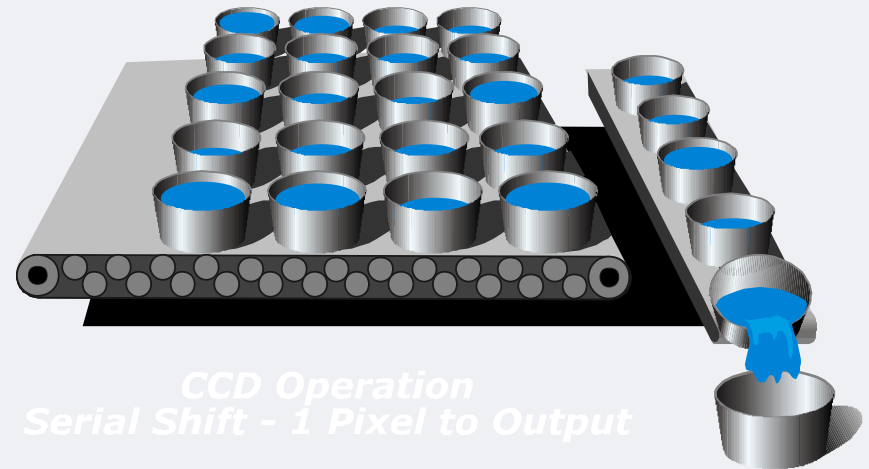

Reading all the buckets - what's my Error?

Dark Current

- Dark Current is created by heat and cosmic noise and can be reduced by cooling
- Dark Current builds over time unlike read noise
- Dark current reduction is sensor dependent
- For example, some sensors will halve dark current for every 7 degrees of cooling; some require more cooling
- Other technologies can be applied which reduce the cooling required

Retiga SRV (cooled to -30) Dark Current 0.15 e/p/s

Exi Blue (cooled to zero) Dark Current 0.005 e/p/s

Photon Shot Noise

- Law of physics
- Square root relationship between signal and noise
- Noise = square root of number of electrons
- Poisson distribution
- When photon noise exceeds system noise, data is photon (shot) noise limited

Signal to Noise

- Standard CCD SNR Equation:

- $SNR = [S * QE] \div \sqrt{[S * QE^2 + D + \sigma_R^2]}$

- S = Signal in Photons (converted to electrons by * QE)
- QE = Quantum Efficiency of light at that emission
- D = Dark Current Noise = Dark Current * Exposure Squared
- σ_R = Read Noise

- All values must be compared in electrons

EMCCD

EM CCD – Electron Multiplied CCD sensors have been in place for over 10 years ago and are used for scientific, military and surveillance applications

Photometrics introduced the first scientific grade camera (Cascade 650) in 2000 to enable customers with low light to achieve higher speed dynamic imaging

Based on CCD technology, the advancement comes from the addition of an Electron Multiplication register enabling higher signals to be achieved relative to the fixed camera noise - Read Noise

The Read Noise Limitation

The low-light level applications are read noise limited
i.e. the signals below the read noise cannot be seen



Read noise limited

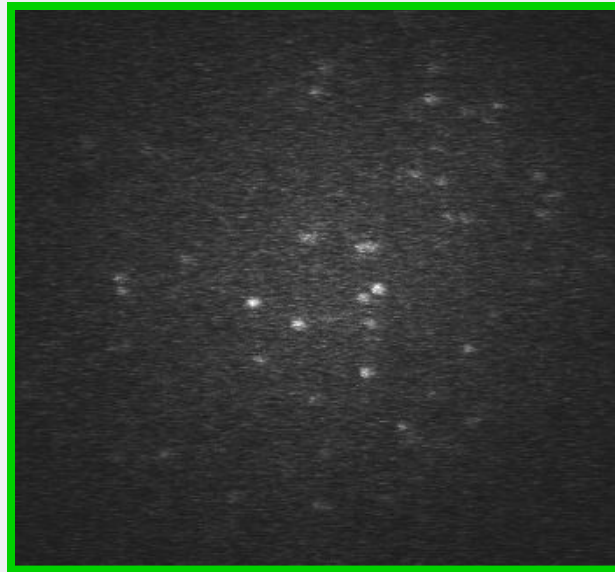

By minimizing the
read noise

Example: single molecule fluorescence

Theory of Operation

On-chip multiplication gain CCD

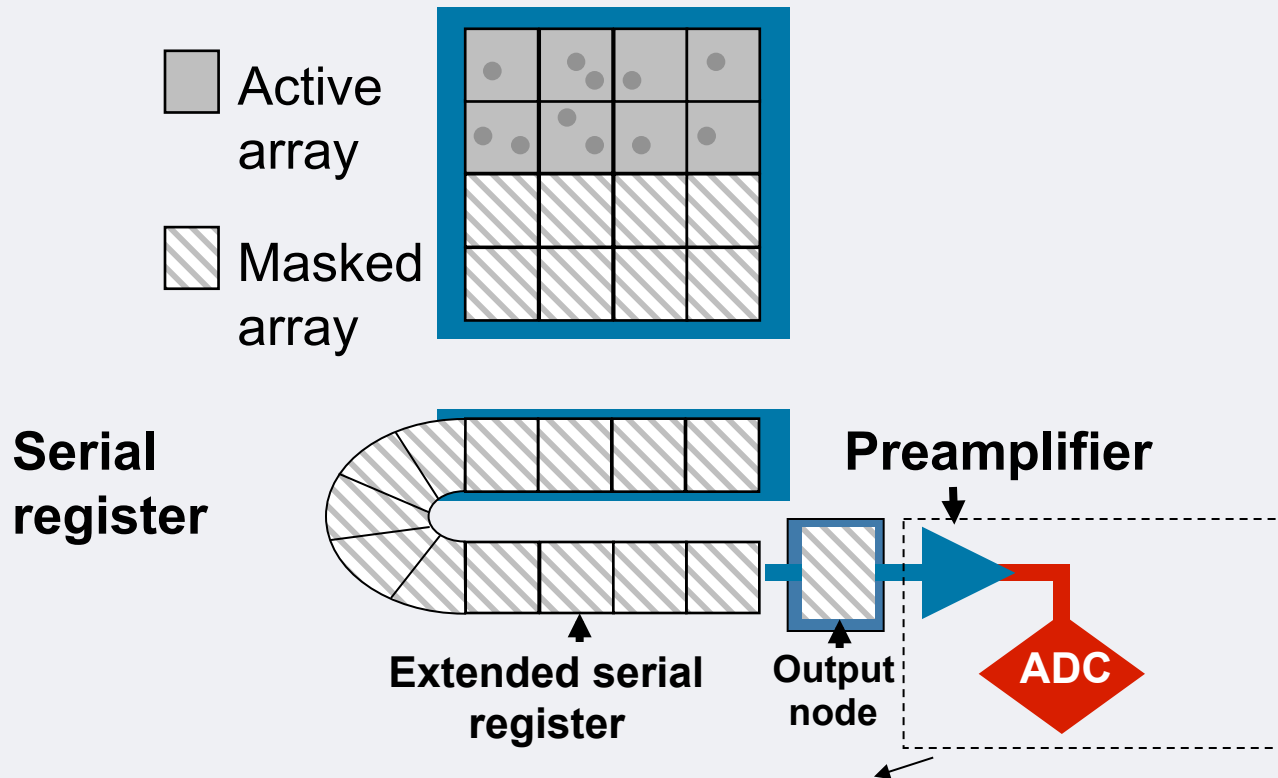

Pre-amp/electronics noise is effectively overcome by multiplying the signal

Serial Register

EM Register

Preamplifier

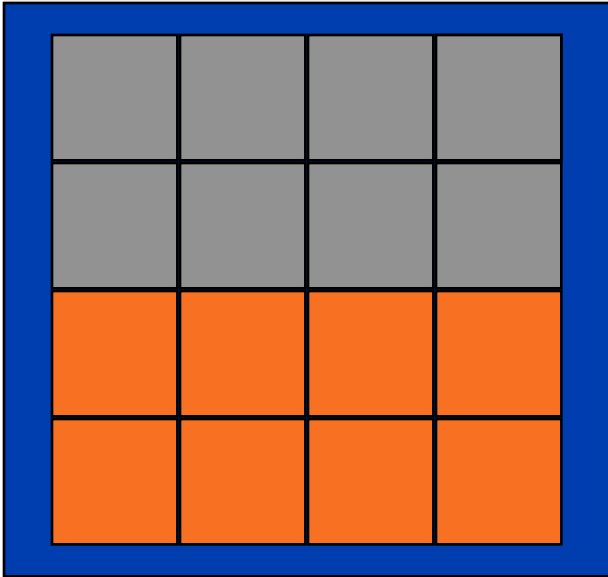
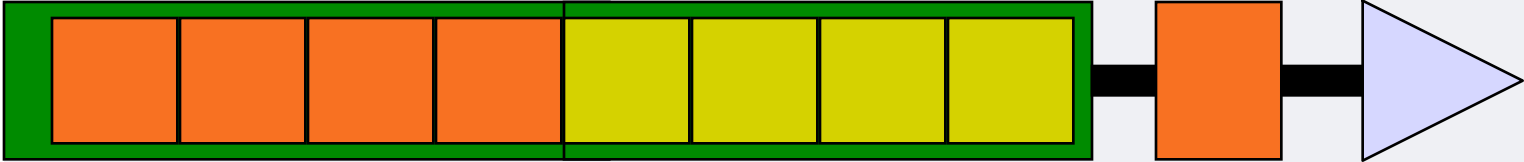

↑
Output Node

Active Array

Serial Register

EM Register

Preamplifier

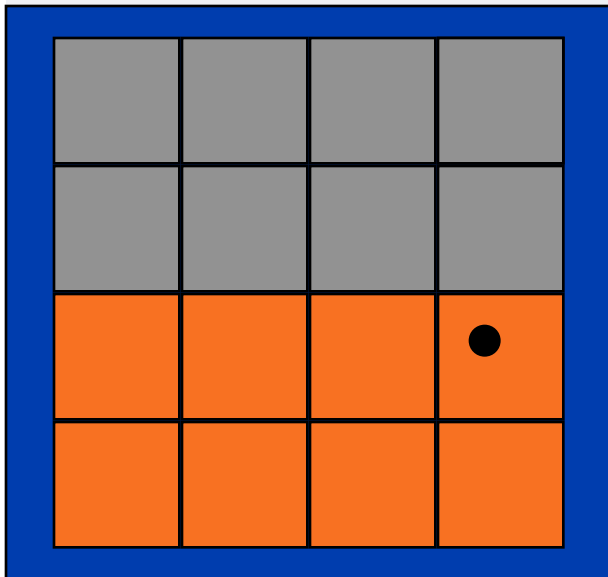
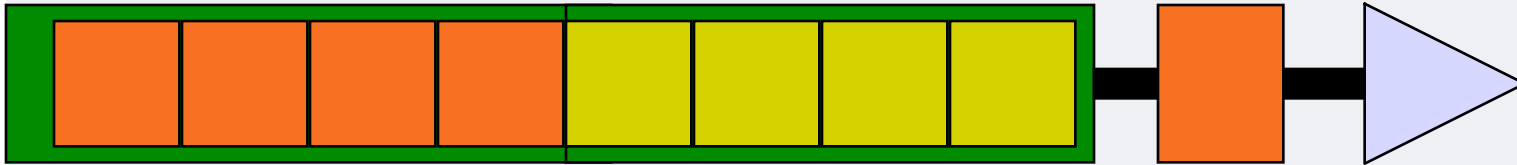

**Output
Node**

Active Array

Serial Register

EM Register

Preamplifier

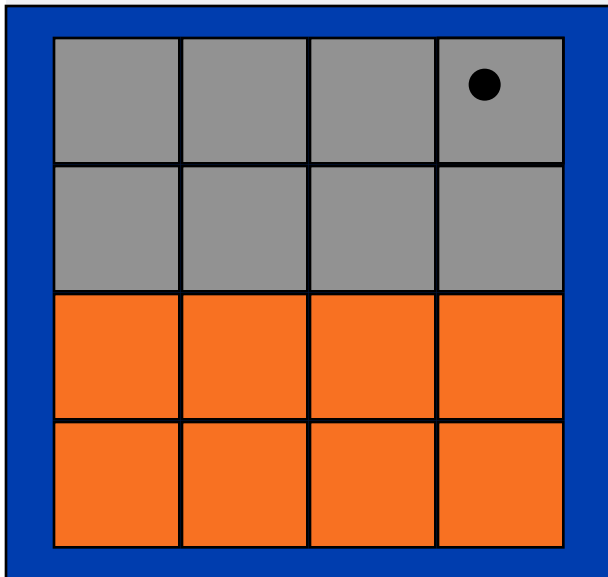
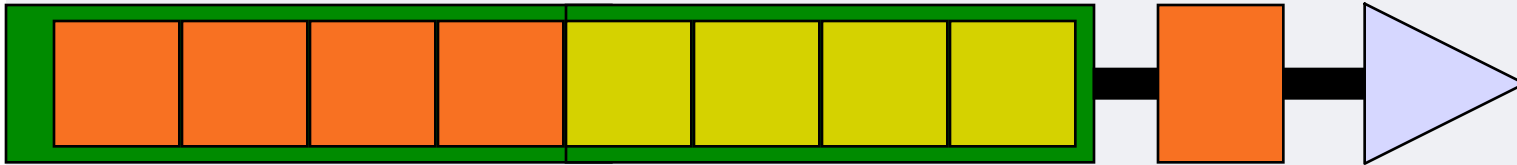

↑
Output Node

Active Array

Serial Register

EM Register

Preamplifier

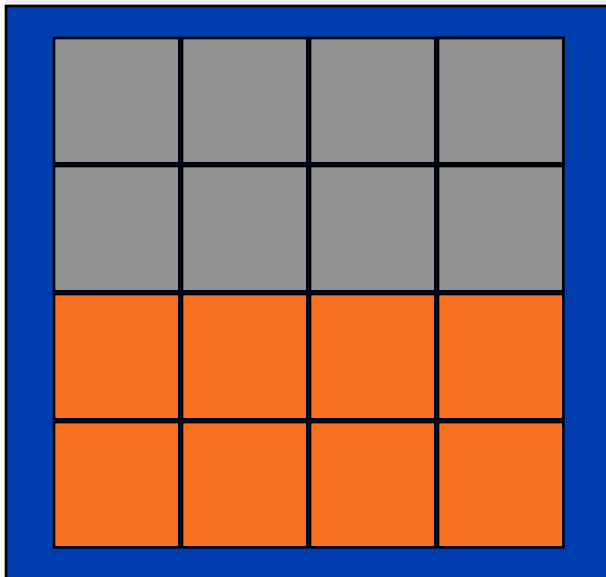
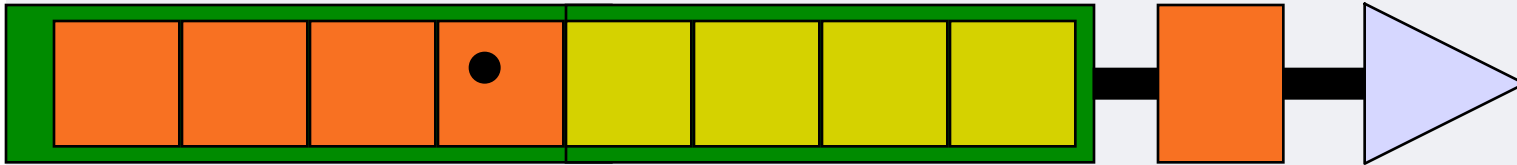

↑
Output Node

Active Array

Serial Register

EM Register

Preamplifier

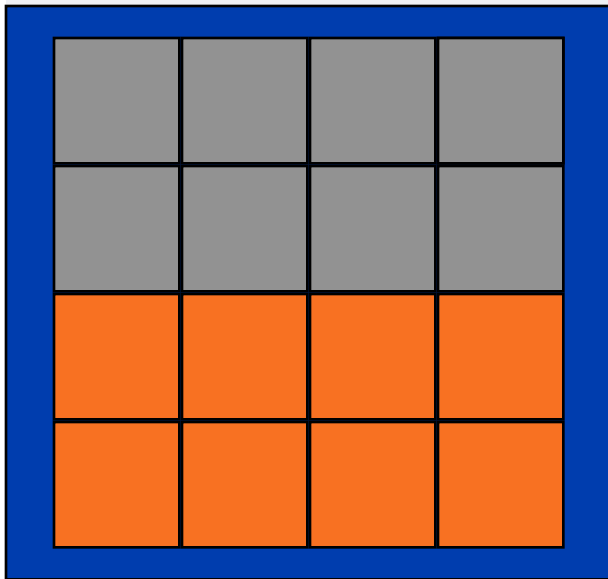
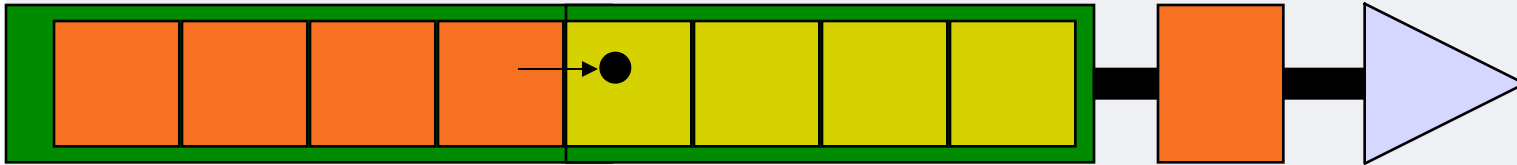

Output Node

Active Array

Serial Register

EM Register

Preamplifier

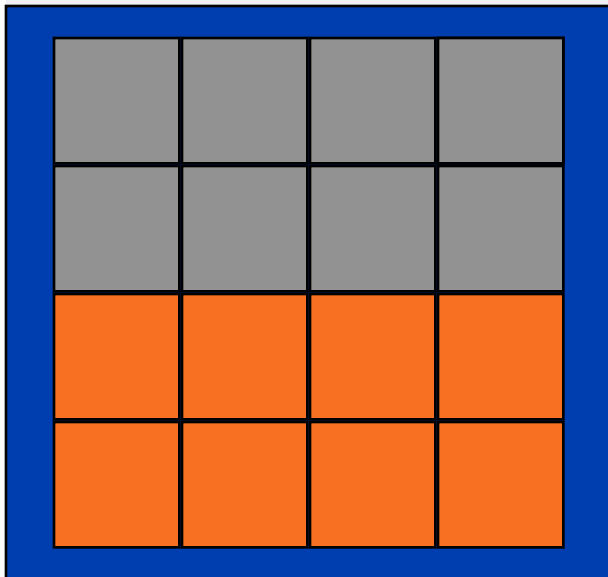
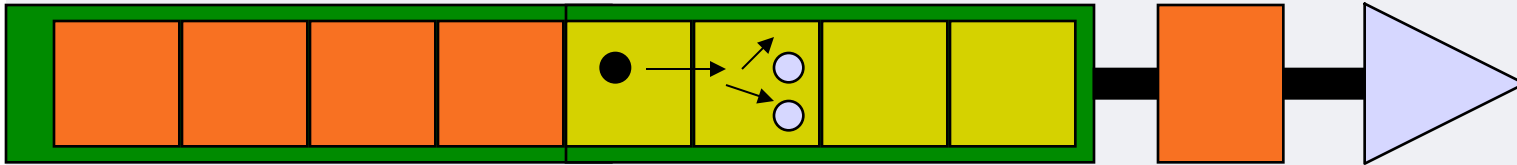

Output Node

Active Array



Serial Register

EM Register

Preamplifier

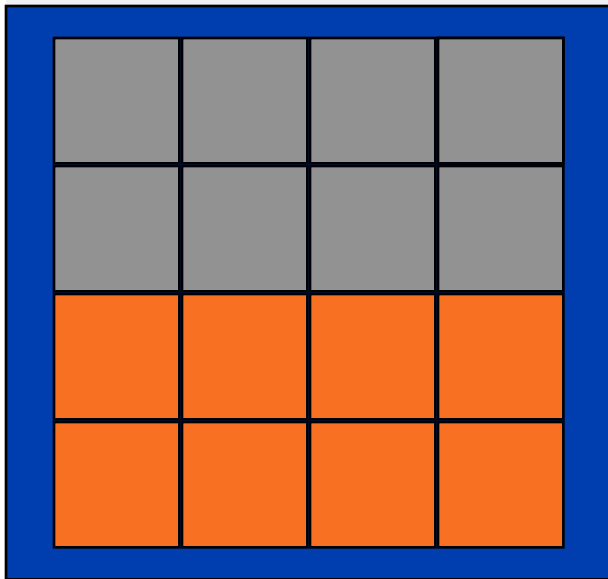
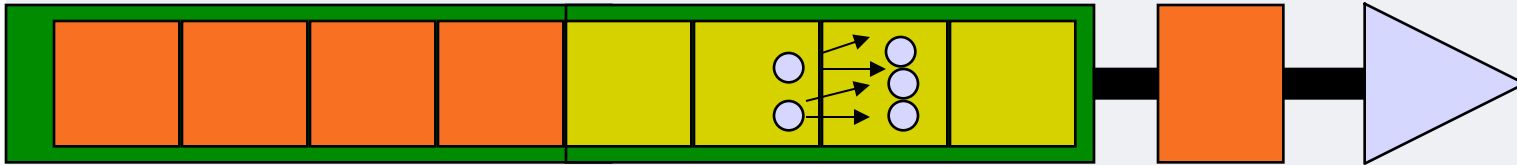

↑
Output Node

Active Array



Serial Register

EM Register

Preamplifier

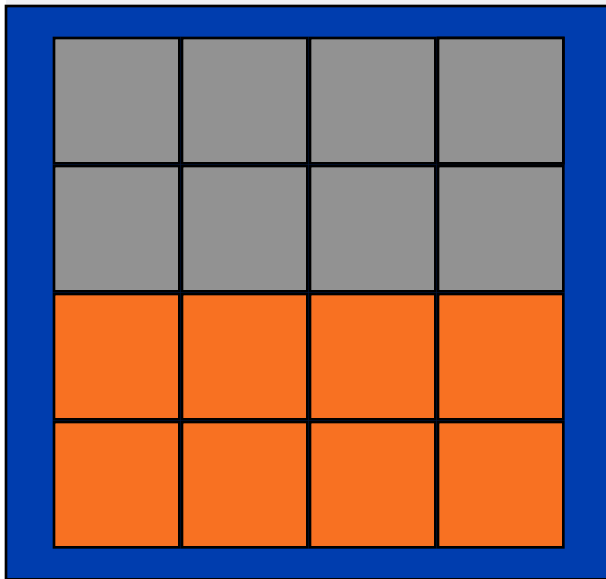
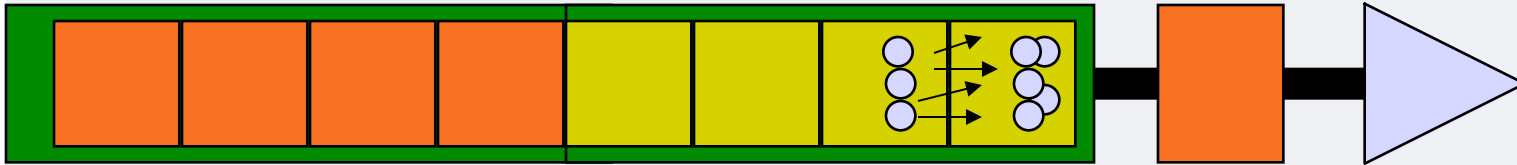

↑
Output Node

Active Array



Serial Register

EM Register

Preamplifier

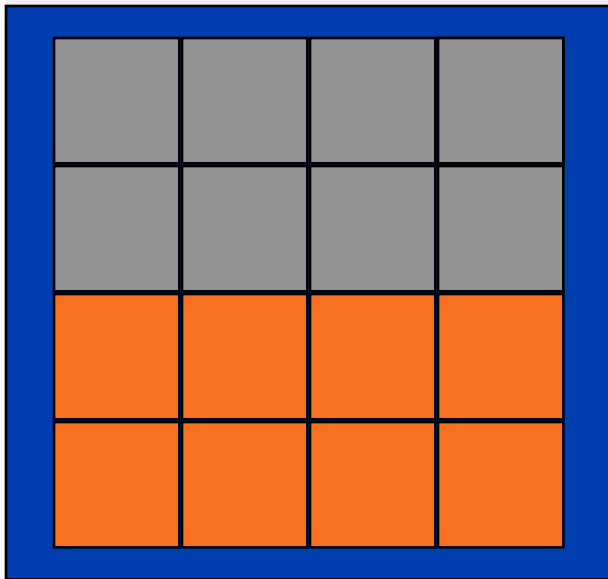
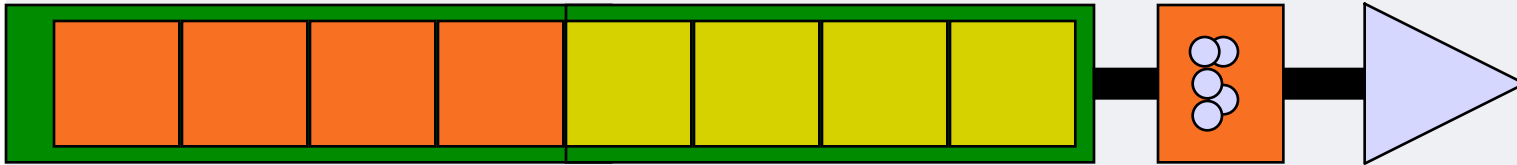

↑
Output Node

Active Array

More detailed look at EMCCD's

- They contain a 'gain register' between the usual serial shift register and the output amplifier.
- Similar to serial register except for R2 phase of the clock cycle which has 2 electrodes
 - 1st held at fixed potential
 - 2nd which is clocked at a much higher voltage amplitude (40-50V) than is required for charge transfer alone.Intense electric field between them causes transferring electrons to cause *impact ionization*
- Note that EMCCDs are subject to aging and that over time the voltage applied will give reducing amounts of ionization.

Electron multiplication / Impact ionization

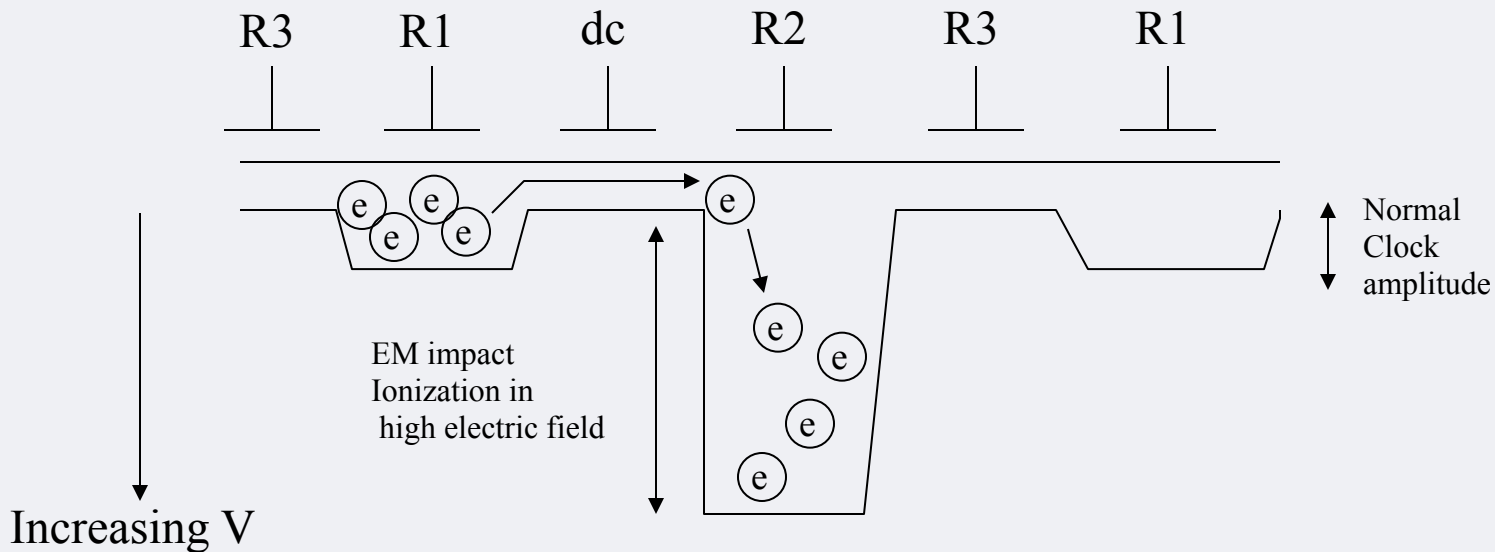

Multiplication per transfer quite small (x1.01 to x1.016). Executed over a large number of transfers leads to significant EM Gain!

Mathematically: $G = (1+g)^N$

G= EM gain, g=probability of secondary electron generation

$1.015^{536} = 2923X$ EM Gain

Issues with EMCCD cameras

- EM Gain decay
- Bias Stability
- EM Gain Stability
- Back ground events – CIC and dark current

- Excess Noise Factor

What is the Excess Noise factor?

- The process of impact ionization is NOT FREE!!
- There is an inherent unpredictability factor of the EM process.
- Some electrons may multiply more than others when going through the extended register.
- This leads to an uncertainty in your measurement, *hence* the excess noise factor.
- Let's look at EMCCD camera noise.

Basic concepts

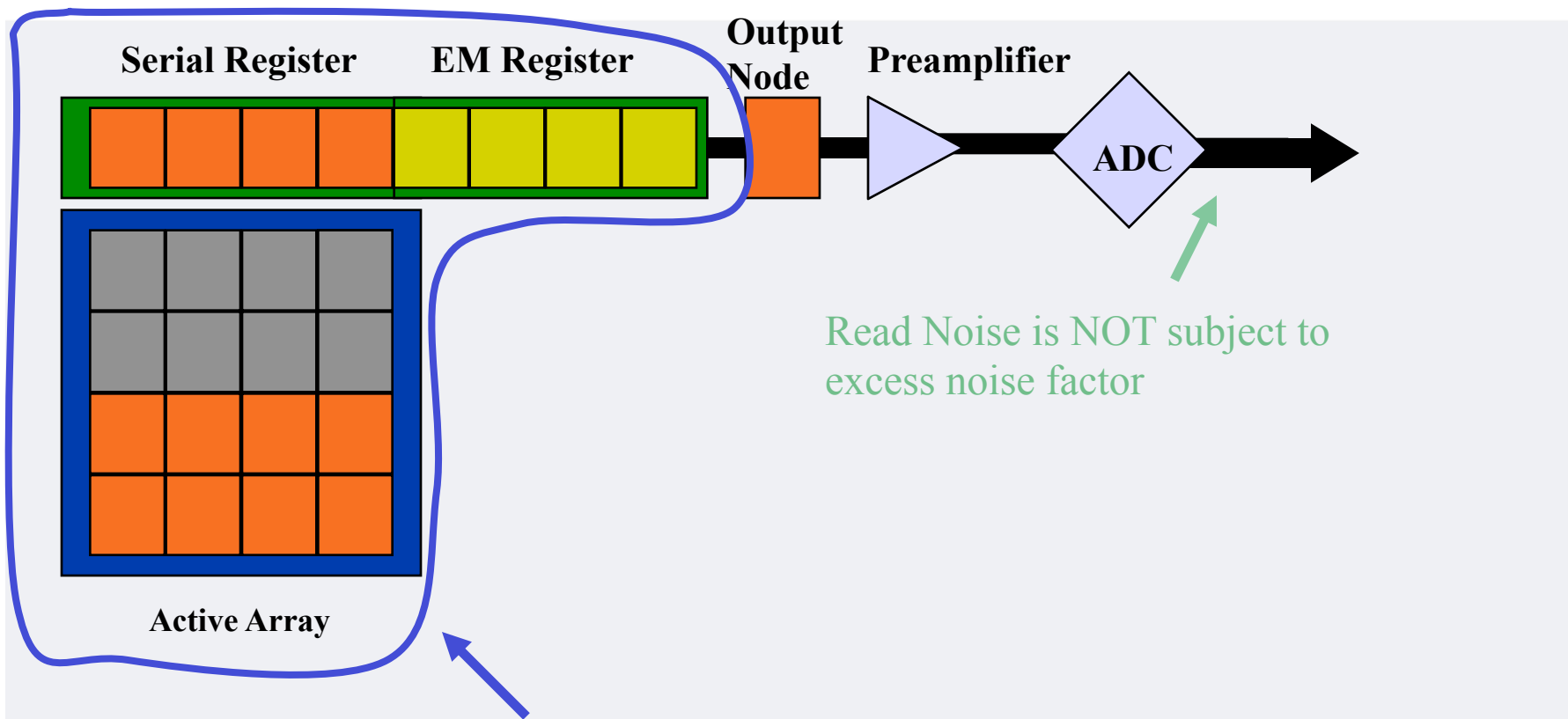

Anything that occurs here is subject to excess noise factor!

e.g. Shot noise, Dark Noise, CIC

Excess Noise – High Signal

- Consider a signal - a typical interline signal of 10,000 electrons
- CCD sensor
- Photon Noise +/-100
- Signal to Noise (assume 6.5e of read) 100:1

- EMCCD sensor
- Photon Noise +/-140
- Signal to Noise (assume 100x EMGain) 77:1

* Note this is slightly unfair as the CCD and EMCCD have different pixel sizes and Quantum Efficiencies

Excess Noise – Low Signal

- Consider a signal a typical interline signal of 20 electrons
- CCD sensor
 - Photon Noise +/- 4.5 e
 - Signal to Noise (assume 6.5e of read) 2.5 :1
- EMCCD sensor
 - Photon Noise +/- 6.3
 - Signal to Noise (assume 100x EMGain) 6.2 :1

* Note this is slightly unfair as the CCD and EMCCD have different pixel sizes and Quantum Efficiencies

SNR: The new equation

On-Chip Multiplication Gain CCD SNR:

$$\text{SNR} = [S*QE] \div \sqrt{[S*QE*F^2 + D*F^2 + (\sigma_R/G)^2]}$$

Note: F is the excess noise factor.

Available sensors

- E2V 997 – 512 by 512 Back illuminated 16 micron pixels
- E2V 201 – 1024 by 1024 Back illuminated 13 micron pixels
- E2V CCD60 128 by 128 Back illuminated 24 micron pixels
- Texas Instruments TC 285 – 1004 by 1002 Front illuminated 8 micron pixel

CMOS

- CMOS as a technology is as old as CCD but was not considered as a sensor capable of light detection until 1992 by Dr. Eric Fossum, a scientist at NASA's Jet Propulsion Laboratory
- CMOS technology, as CCD, uses an array of light sensitive pixels to collect full area image
- CMOS technology differs by completing all digitisation at the pixel point rather than needing to read the signal and then digitise
- CMOS sensors also, by nature, require around 100x less power than CCD making them the perfect choice for camera phone sensors
- As sensors are mass produced for mobile phone imaging and also for non-imaging applications, the pricing has been driven low by the market



CMOS Sensors

- Advantages of CMOS
 - High resolution sensors
 - Fast
 - Low power consumption
 - Low cost
- Disadvantages
 - Small pixels so low Dynamic range
 - High noise level
 - Rolling shutter
 - Lower QE

Making CMOS Scientific

- July 2009 3 camera manufacturers launched a white paper on a new type of camera technology called SCMOS (scientific CMOS) – Camera became available for mass market late 2011
- Aim was to make a new sensor that had all the advantages of traditional CMOS sensors but remove the disadvantages making a sensor that is:
 - Low noise – less than $2e$ read noise
 - High speed – 100 fps
 - High QE – 55-70%
 - High resolution – 2-5 million pixel
 - 6.5 μ m pixel – Good size for microscopy

Read Noise

CCD Readout

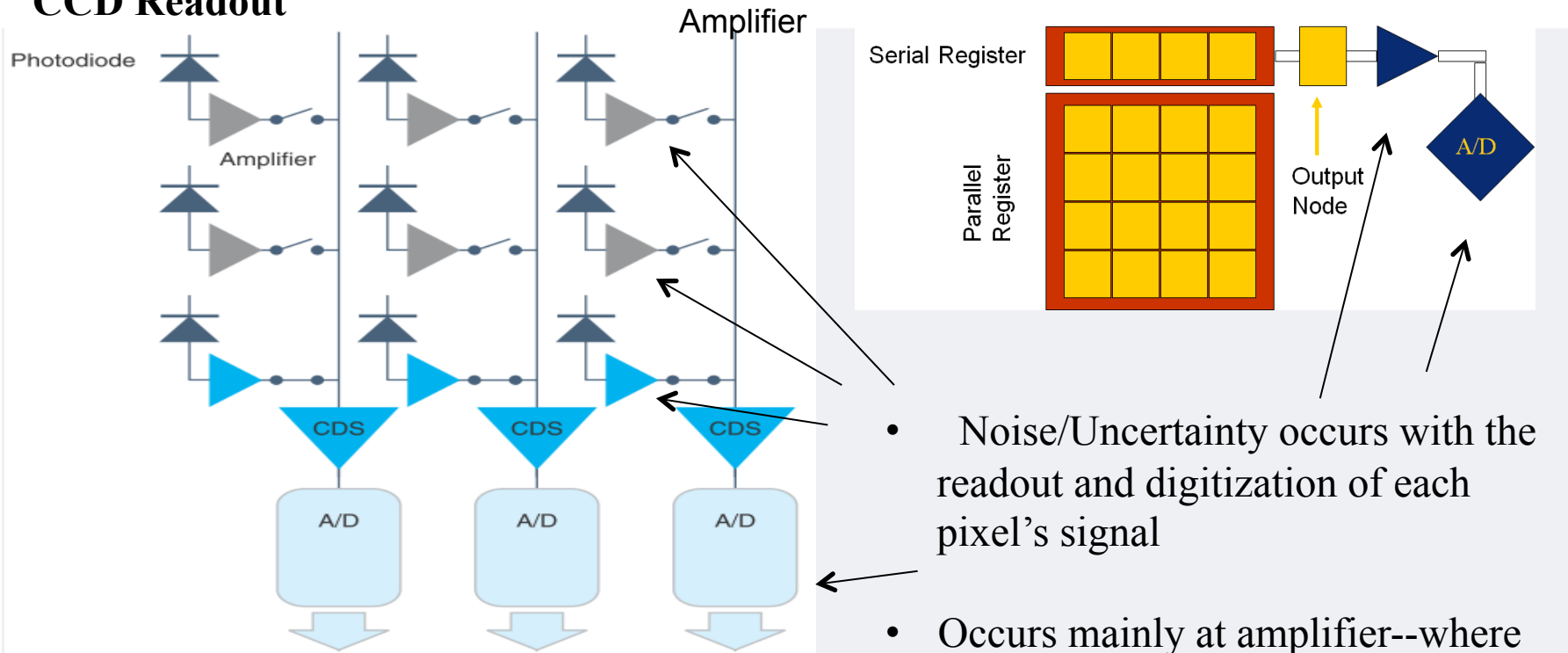

- Noise/Uncertainty occurs with the readout and digitization of each pixel's signal
- Occurs mainly at amplifier--where electron charge are converted to analog voltage--and at analog-to-digital converter

- Amplifier for each pixel and a different A/D converter for each column

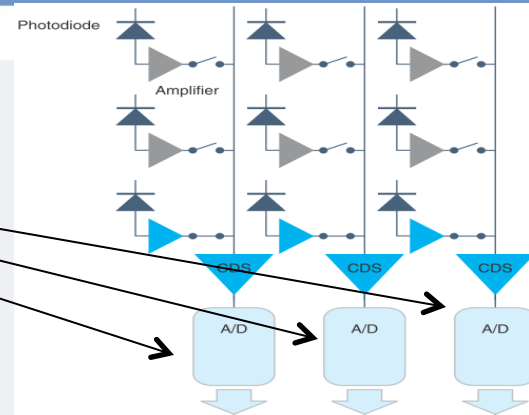

But at the expense of column-to-column variation...

- Poor column-to-column variation, especially at higher intensities

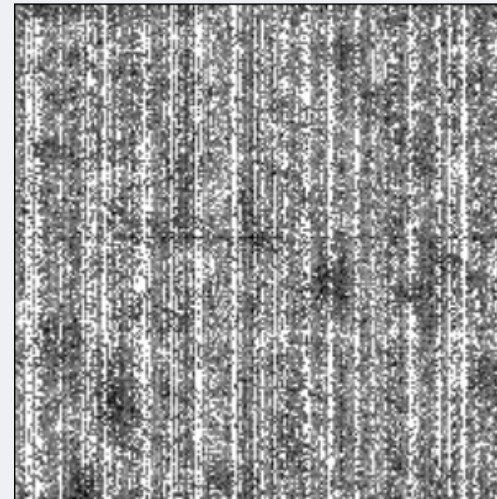

200x200 Region at High Light

What does this mean?

- Faster Speeds are achievable for high resolutions
- Low Noise is possible at speed
- Lines are often visible in bias where a more even background/bias is observed with a CCD
- Correction is being done on the camera to make the images useful (uniform bias and linear response to light)

sCMOS Random Telegraph Noise

- sCMOS cameras exhibit additional noise during readout, known as Random Telegraph Noise

- This noise is due to charge moving in and out of a pixel defect

- Top Graph to the right:

- Output of single pixel with a defect measured over time
- SHS and SHR represent the constant sampling of the pixel
- The digital output of a pixel is measured as the difference between SHR and SHS
- If an electron moves into or out of a pixel defect between reference signal and sample signal, a delta is measured, and the pixel shows either a higher or lower intensity

- Bottom Graph to the right:

- Statistical frequency of pixel intensity changes

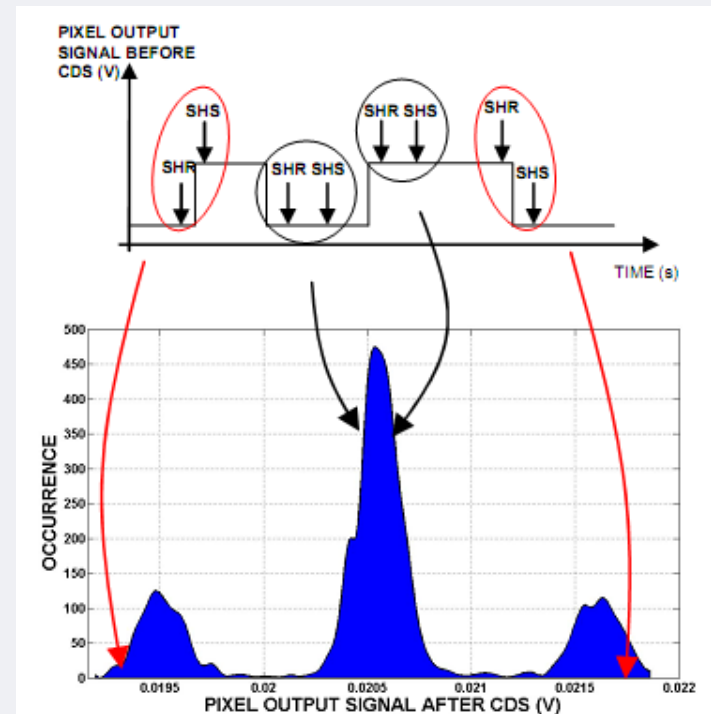

SHS = Sampled Signal; SHR = Reference Signal

Scientific CMOS Noise Distribution

- Tailing in skewed noise histogram instead of standard Gaussian due to Random Telegraph Noise

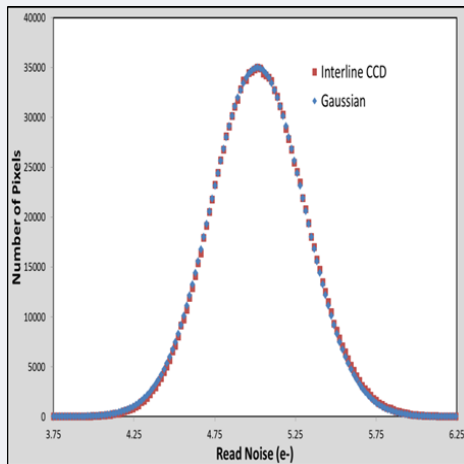

CCD Noise Histogram

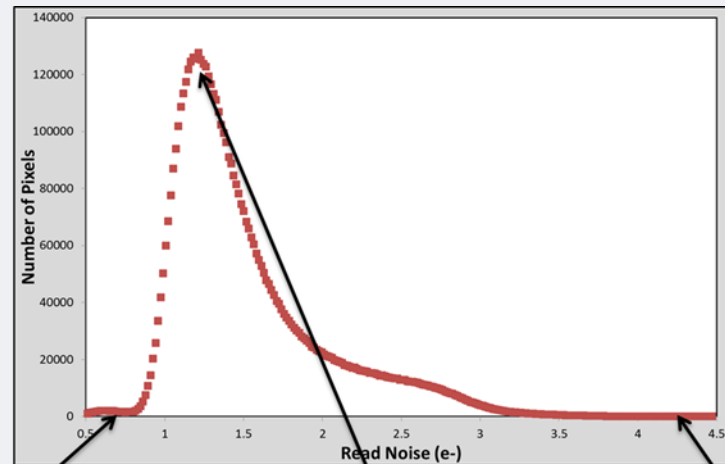

Low Noise Pixel

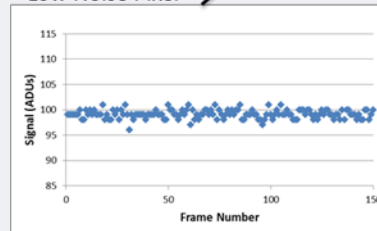

Medium Noise Pixel

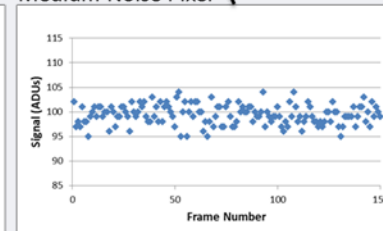

High Noise Pixel

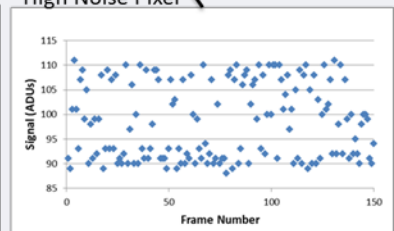

What does this mean?

- Bias can look more noisy than a CCD (although its not) due to this “salt and pepper” noise
- Noise characteristics are different and this would need to be taken into account with any statistical modeling.
- Again, correction is done on the camera to remove the problem (though this correction can cause issues for some applications)

Notes

- Some noise can be removed by using on-board processing like BERT
- Around 10-20% of the pixels behave in this way

Rolling Shutter

- CCD's shutter all pixels at an identical time leading to single snap shot in time
- CMOS sensors are read/shutter different pixels at different time meaning you have a chance for a distortion.
- This shuttering process is known as “**Rolling Shutter**”

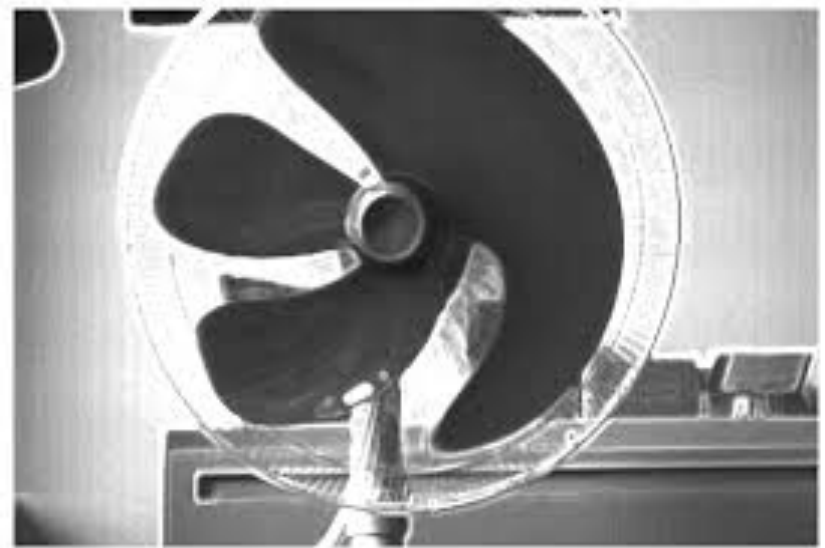

Rolling Shutter

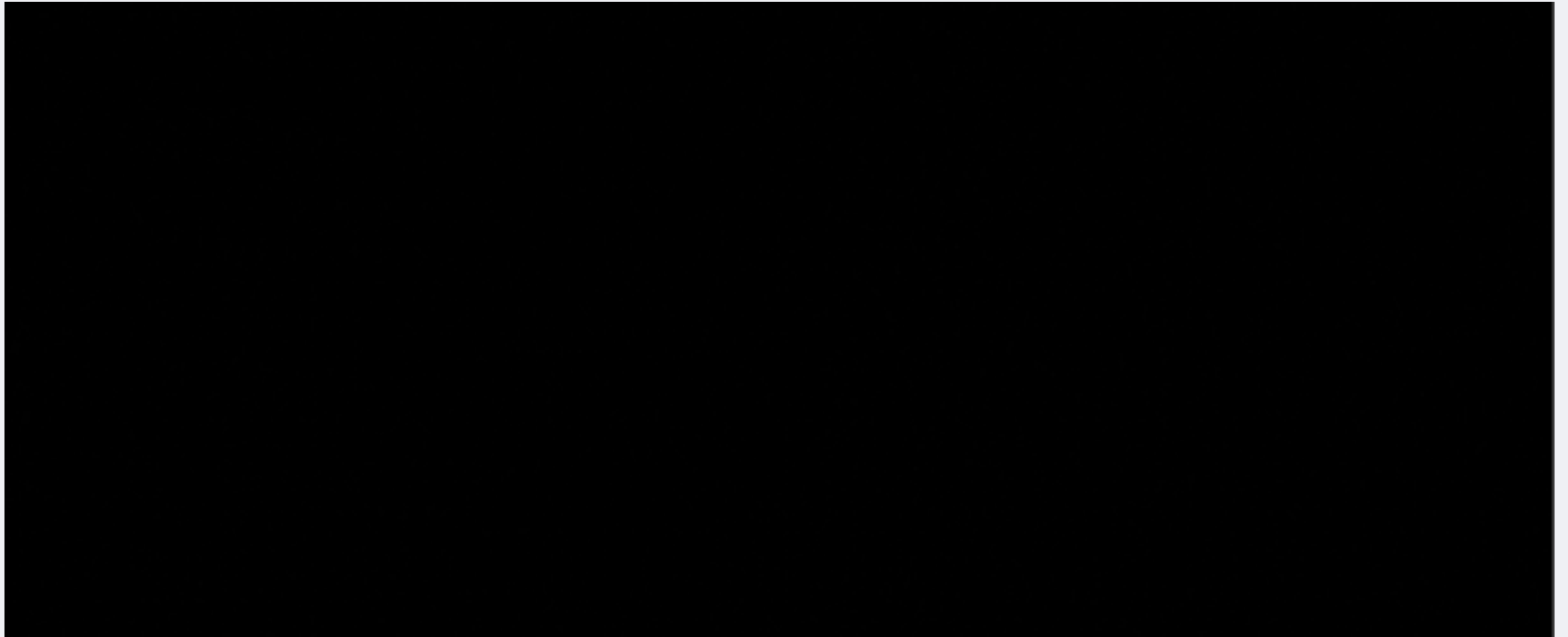

Rolling Shutter



Rolling Shutter Readout Mode

- Exposure time is limited to multiples of the line time
 - CIS1910 = 2464 (clock cycles per row) ÷ Readout Frequency
 - At 283 MHz, minimum line time = $2464/283,000,000 = 8.71\mu\text{s}$
 - Each row is offset by one line's readout time from the previous row
 - Last row starts exposure nearly 1 frame's time after the start of the first row
 - $1079 \text{ rows} \times 8.71\mu\text{s} = 9.4\text{ms} = \text{minimum temporal resolution}$

Rolling Shutter Exposure: Row by Row Exposure Start/End Offset

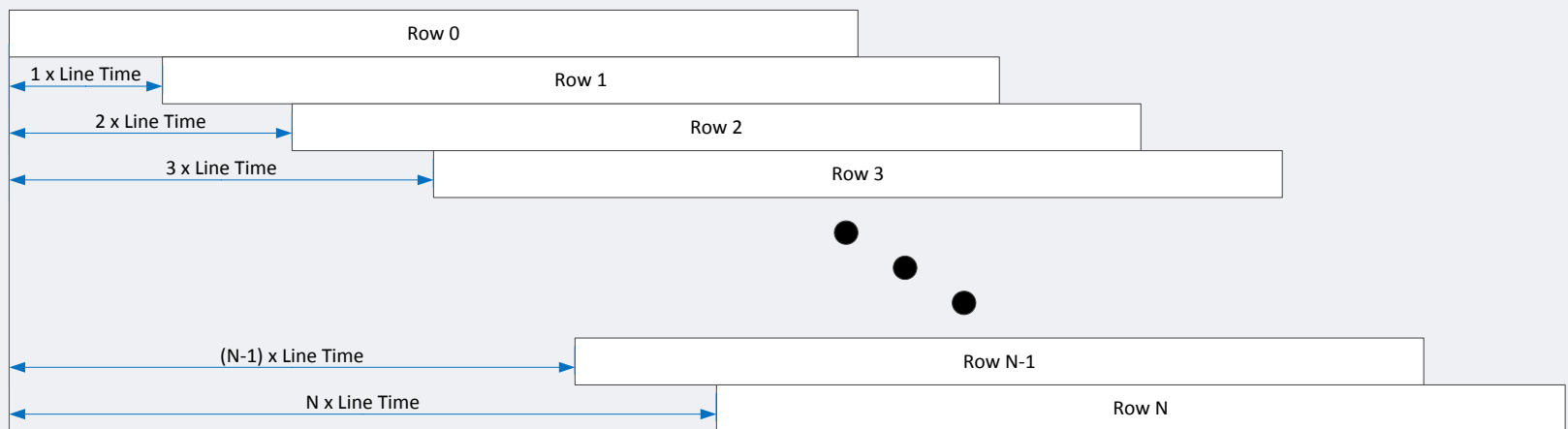

What does this mean?

- Possible distortion of moving objects
- Poor synchronization with changing illumination experiments
- Some experiments may require a “Global” shutter

Notes

- A global shutter effect can be achieved with use of triggering if the system light source will allow (lasers, LED). This will come at the price of frame rate

Conclusions

- CCD cameras have been the standard for general microscopy applications for many years and will continue to be the best choice for a variety of applications from colour imaging and fixed sample fluorescence to 'long stare applications'
- EMCCD cameras continue to offer the best solution when imaging at very low light levels with speed, for example single molecule fluorescence
- sCMOS is a fantastic new addition to the sensors available for microscopy when speed is key. Combining this with great sensitivity a large field of view and low noise. Well suited to applications such as SPIM.

FIN