

# Lecture 2 - 2014

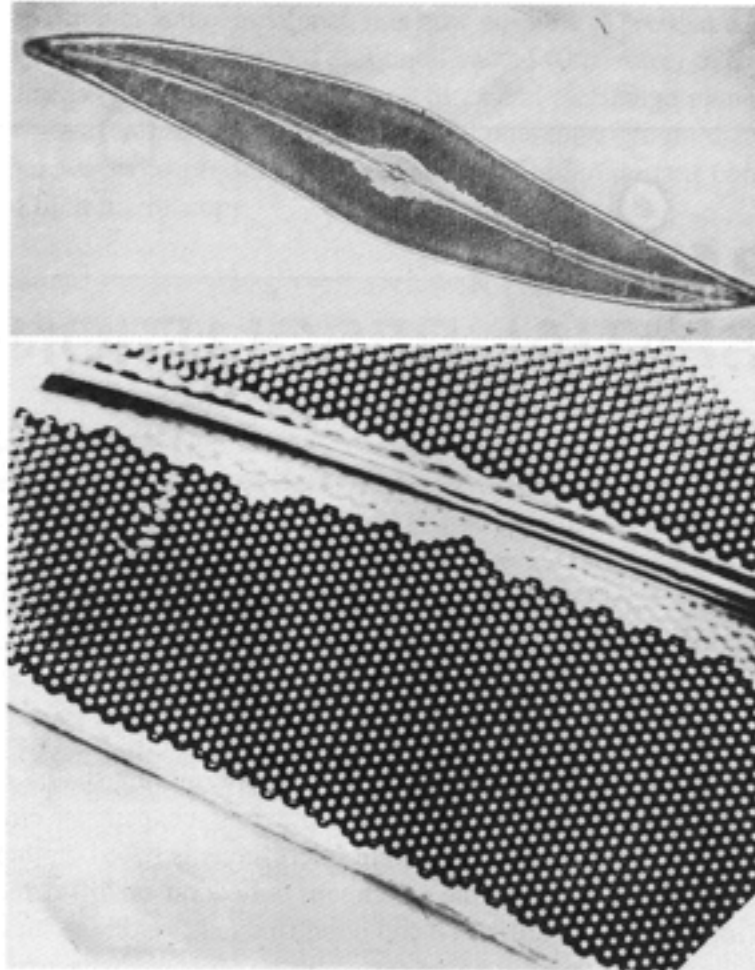

# Microscope anatomy, image formation and resolution

Ian Dobbie - [ian.dobbie@bioch.ox.ac.uk](mailto:ian.dobbie@bioch.ox.ac.uk)  
x13323     [micron@bioch.ox.ac.uk](mailto:micron@bioch.ox.ac.uk)

**Buy this book for your lab:**

D.B. Murphy, "Fundamentals of light microscopy and  
electronic imaging", ISBN 0-471-25391-X

**Visit these websites:**

<http://www.microscopyu.com>

<http://www.olympusmicro.com>

# Key points

- Basic understanding of refraction and diffraction, and properties of lenses
- Understanding of two different sets of conjugate planes, especially importance of objective back-focal plane
- Understanding of factors affecting image resolution

# What a microscope needs to do

- Magnify things
- Resolve points which are close together
- Collect as much light as possible (esp. for fluorescence)
- Do all of the above while introducing as little distortion as possible

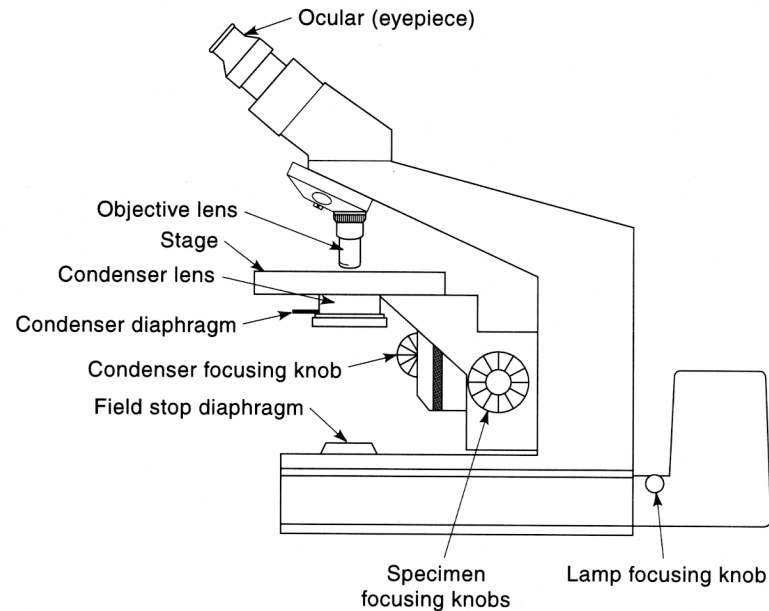

Figure 1-1

The compound light microscope. Note the locations of the specimen focus dials, the condenser focus dial, and the focus dial of the collector lens on the lamp housing. Also note the positions of two variable iris diaphragms: the field stop diaphragm near the illuminator, and the condenser diaphragm at the front aperture of the condenser. Each has an optimum setting in the properly adjusted microscope.



# We need to understand the nature of light

- Image formation in the light microscope depends exclusively on the interactions of light with matter
- **Diffraction:** scattering of the incident illuminating light by the detailed substructure with the specimen
- **Refraction:** "bending" of light, by a lens, which causes scattered light to converge, to form an image

# Light as electromagnetic radiation

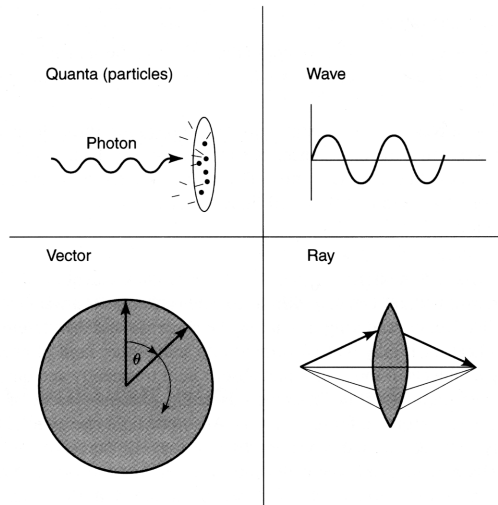

Figure 2-4  
Light as quanta, waves, vectors, and rays.

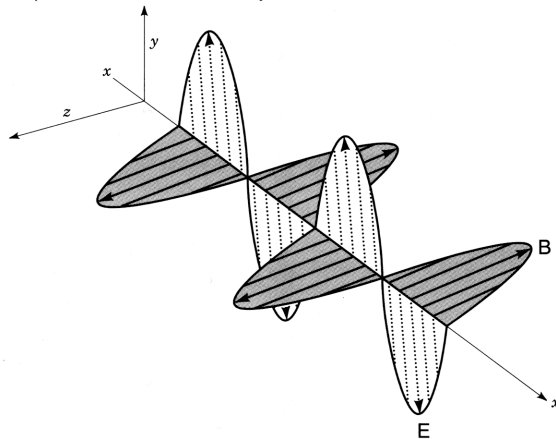

Figure 2-2  
Light as an electromagnetic wave. The wave exhibits electric (E) and magnetic (B) fields whose amplitudes oscillate as a sine function over dimensions of space or time. The amplitudes of the electric and magnetic components at a particular instant or location are described as vectors that vibrate in two planes perpendicular to each other and perpendicular to the direction of propagation. However, at any given time or distance the E and B vectors are equal in amplitude and phase. For convenience it is common to show only the electric field vector (E vector) of a wave in graphs and diagrams and not specify it as such.

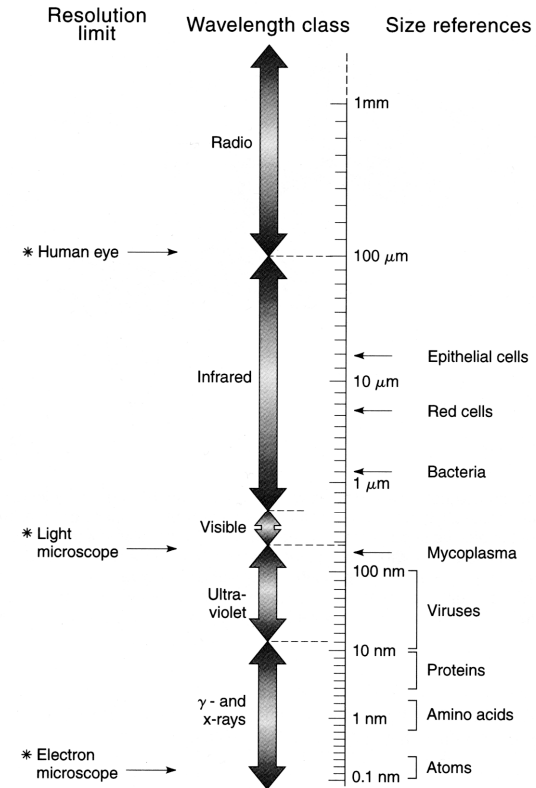

Figure 2-3  
The electromagnetic spectrum. The figure shows a logarithmic distance scale (range, 1 mm to 0.1 nm). One side shows the wavelength ranges of common classes of electromagnetic radiation; for reference, the other side indicates the sizes of various cells and macromolecules. Thus, a red blood cell (7.5  $\mu\text{m}$ ) is 15 times larger than a wavelength of visible green light (500 nm). The resolution limits of the eye, light microscope, and electron microscope are also indicated. For the eye, the resolution limit (0.1 mm) is taken as the smallest interval in an alternating pattern of black and white bars on a sheet of paper held 25 cm in front of the eye under conditions of bright illumination. Notice that the range of visible wavelengths spans just a small portion of the spectrum.

# How lenses work

- Refraction--the "bending", or change in the direction, of light
- Explaining refraction doesn't require the "wave" formalism, just the rays
- The speed of light depends on the medium through which light is propagating
- Refraction occurs when light rays travelling through one type of medium meet an interface with another type of medium
- The extent of refraction depends on the angle of incidence (Snell's law)

$$n_1 \sin \theta_1 = n_2 \sin \theta_2$$

Here the light ray is *orthogonal* to the interface

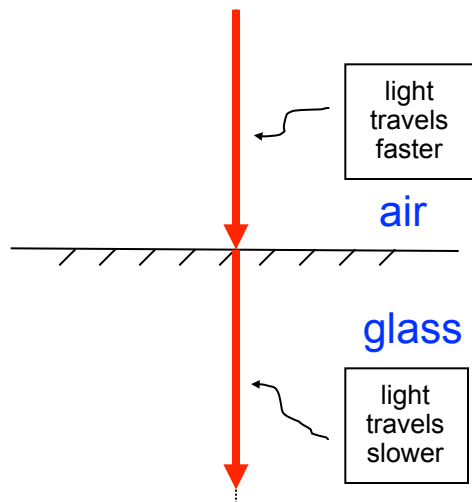

Here the light ray is *oblique* to the interface

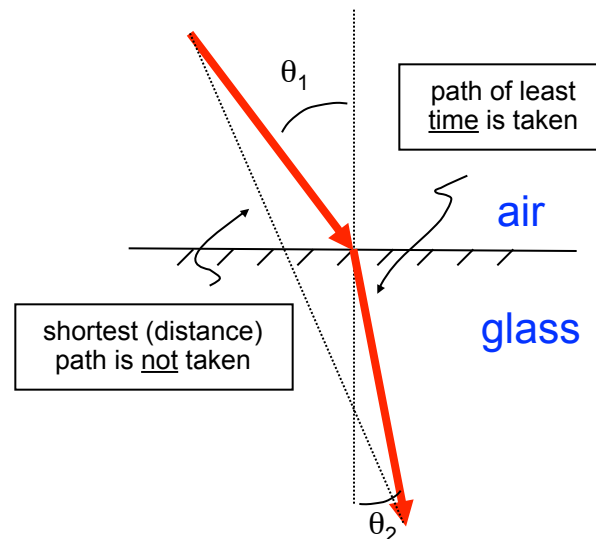

More dense materials have higher refractive indices:

Air	1.0003
Water	1.33
Glycerin	1.47
Immersion Oil	1.515 (e.g.)
Glass	1.52
Flint	1.66
Zircon	1.92
Diamond	2.42
Lead Sulfide	3.91

$$n_i = c/v_i$$

# Lensing occurs when the interface is curved

- Positive (convex) lenses converge light rays. Light rays that would otherwise never meet (e.g. because they are parallel, or diverging) can now do so.
- Negative lenses (concave) diverge light rays

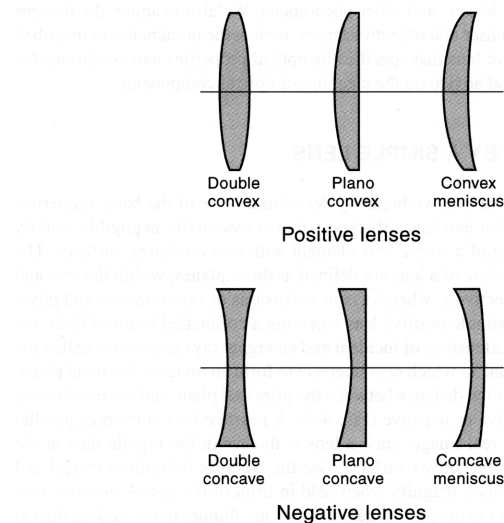
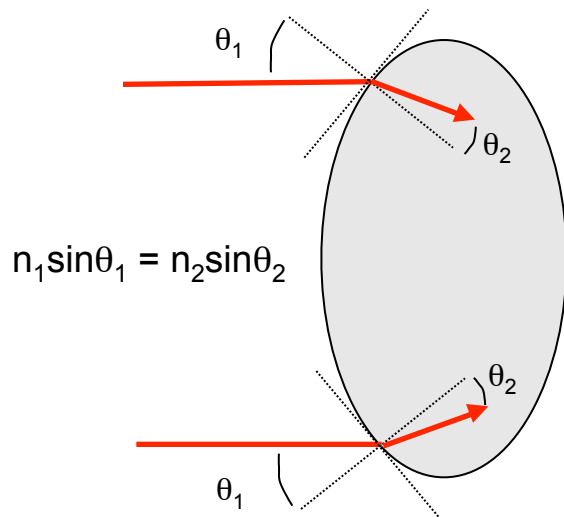

Figure 4-2  
Examples of positive and negative lenses.

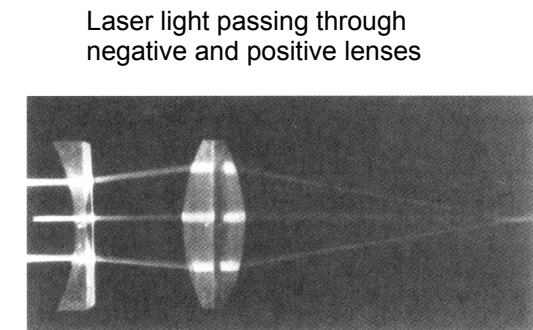

Figure 4-1  
Geometrical optics of a positive lens. (From Hecht, 1998.)

# Image position and magnification depend on lens curvature (focal length) and on the physical distance from the object to the lens

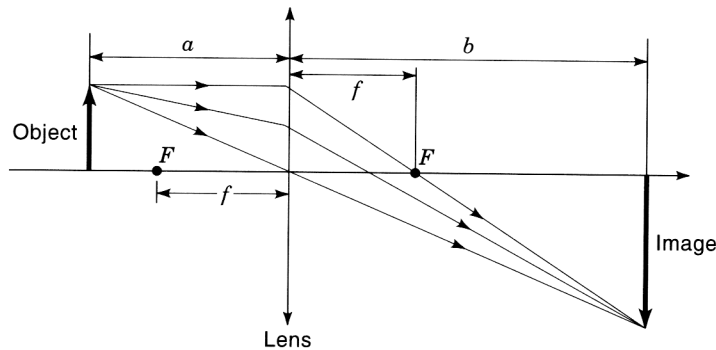

Figure 4-3

Geometrical optics of a simple lens. The focal length  $f$ , focal point  $F$ , object-lens distance  $a$ , and lens-image distance  $b$  are indicated.

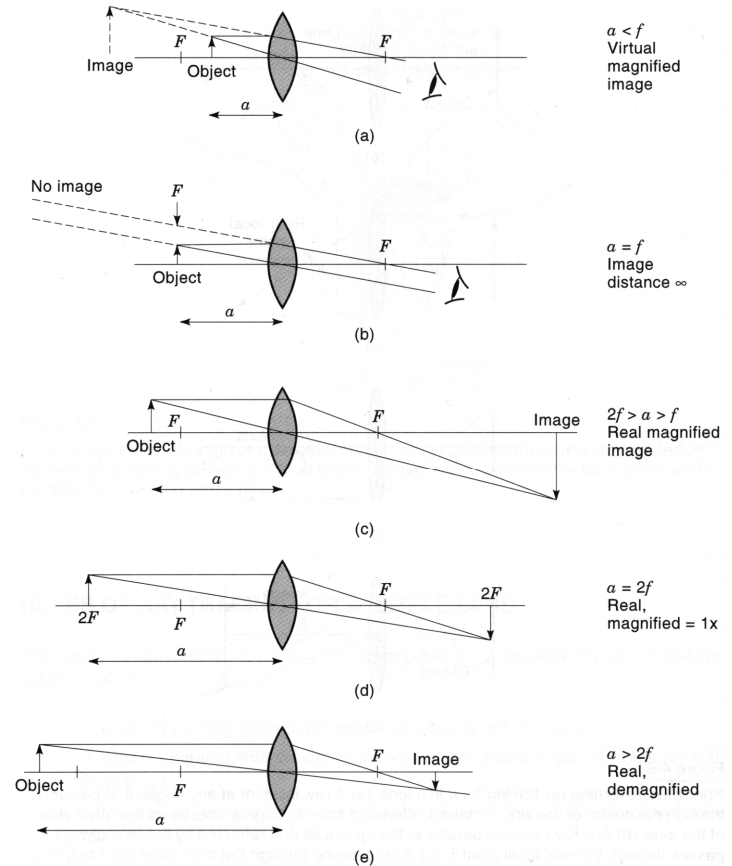

Figure 4-6

Object-image relationships. (a)  $a < f$ ; (b)  $a = f$ ; (c)  $2f > a > f$ ; (d)  $a = 2f$ ; (e)  $a > 2f$ .

# All simple lenses have associated aberrations

- Still may encounter: *chromatic aberration* on cheap microscopes (prism effect--but can be reduced by using monochromatic light), *spherical aberration* when imaging deep into samples (e.g. embryos, even when the objective is "corrected"), *field curvature* when using bright lenses for fluorescence (but this is not a problem if you're imaging cells only in the center of the field)

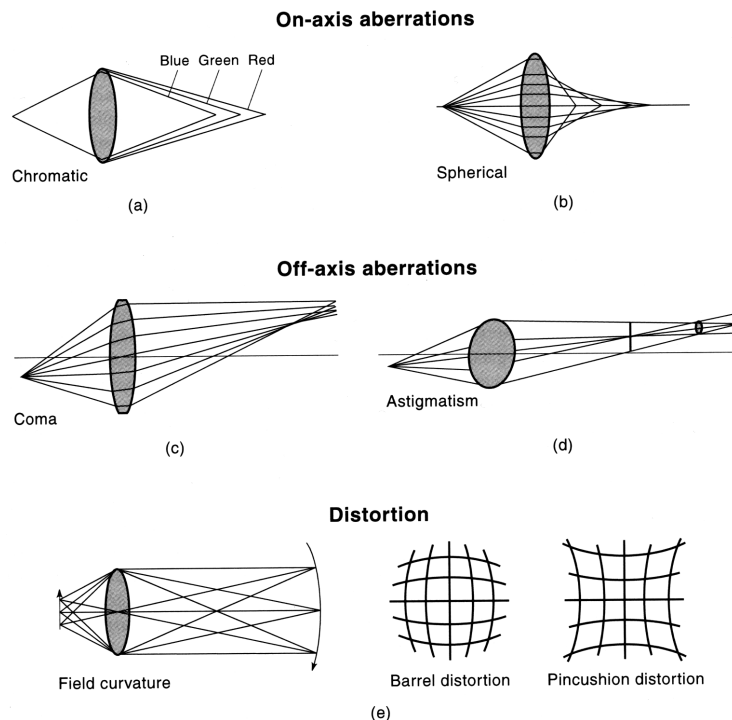

Figure 4-8

Aberrations of a simple lens. (a) Chromatic aberration: Parallel incident rays of different wavelength are focused at different locations. (b) Spherical aberration: Incident rays parallel to the optic axis and reaching the center and the periphery of the lens are focused at different locations. (c) Coma: Off-axis rays passing through the center and periphery of the lens are focused at different locations. (d) Astigmatism: An off-axis aberration causes waves passing through the vertical and horizontal diameters to focus an object point as a streak. (e) Distortion and field curvature: The image plane is curved and not planar. So-called barrel and pincushion distortions produce images that are not high in fidelity compared to the object.

More lens elements = better correction, but also possibly less light throughput

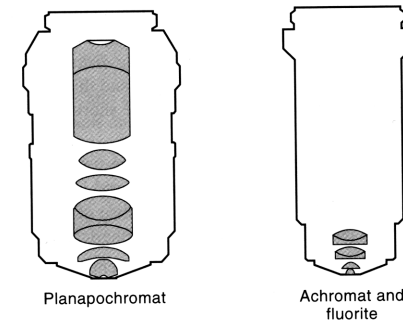

Figure 4-9

Objective lens designs. Two popular lenses for fluorescence microscopy are shown. Apochromatic lenses may contain 12 or more lens elements to give bright, flat images with excellent color correction across the visual spectrum. Fluorite lenses have fewer lens components and produce sharp, bright images. These lenses exhibit excellent color correction and transmit UV light.

Achromat = corrected for 2 colors

Apochromat = corrected for 3 colors

Plan = flat-field (although not always to full limits of field of view)

TEST BEFORE BUYING!!

# Image formation in the context of a real microscope

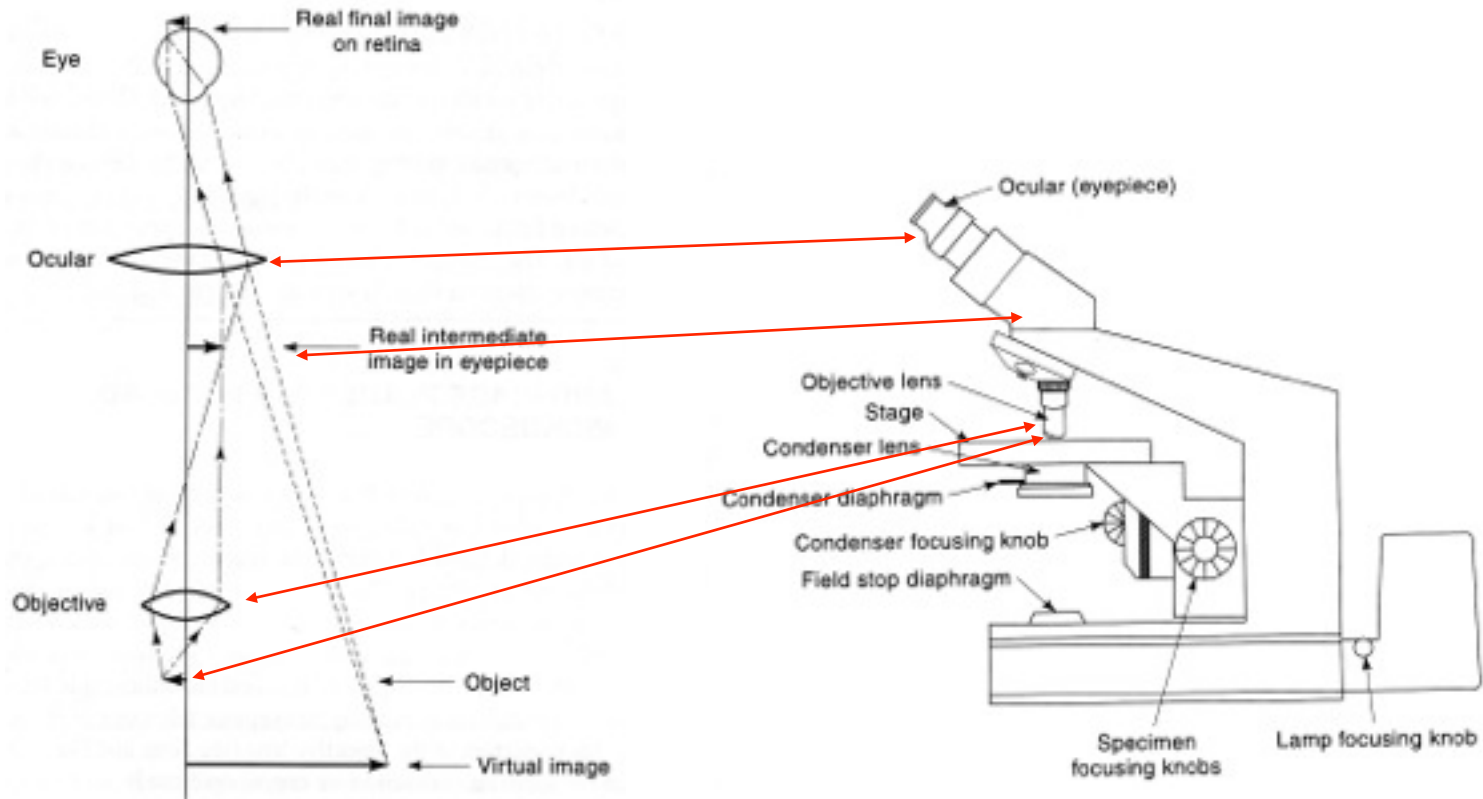

# Koehler illumination emphasizes the difference between imaging planes and illumination planes

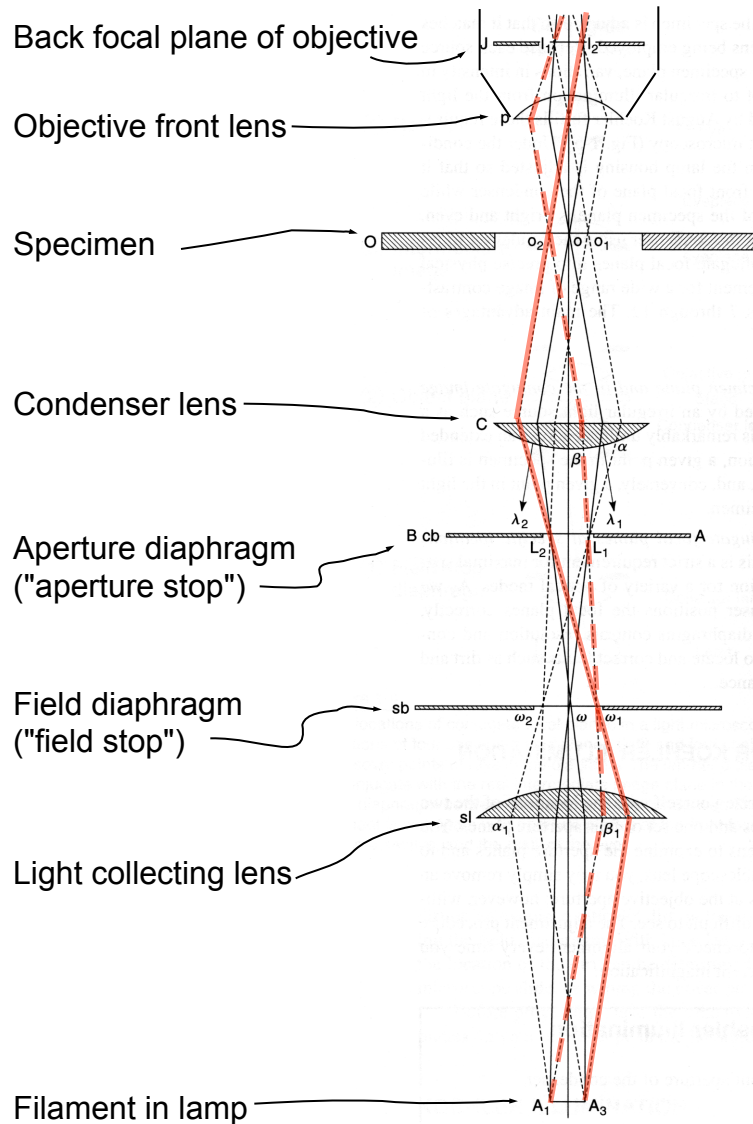

August Kohler  
1866-1948

- To reduce artifacts, Kohler introduced the light collecting lens and adjusted the condenser position such that the lamp filament is maximally out-of-focus at the specimen plane.
- This innovation is essential to all modern microscopy--the main adjustment we make with transmitted light microscopy is to "Koehler" the microscope by focussing the condenser.
- Koehler illumination highlights a special relationship between two sets of planes in the microscope light path.



# Koehler illumination emphasizes the difference between imaging planes and illumination planes

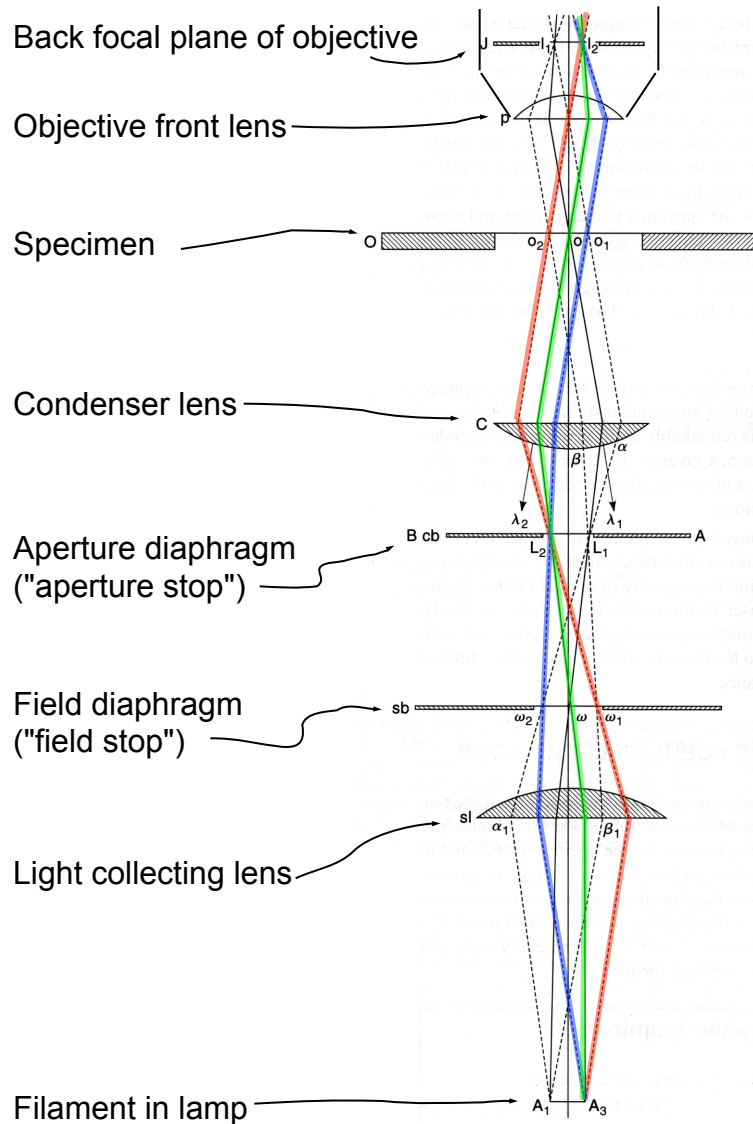

August Kohler  
1866-1948

- To reduce artifacts, Kohler introduced the light collecting lens and adjusted the condenser position such that the lamp filament is maximally out-of-focus at the specimen plane.
- This innovation is essential to all modern microscopy--the main adjustment we make with transmitted light microscopy is to "Koehler" the microscope by focussing the condenser.
- Koehler illumination highlights a special relationship between two sets of planes in the microscope light path.

# Koehler illumination emphasizes the difference between imaging planes and illumination planes

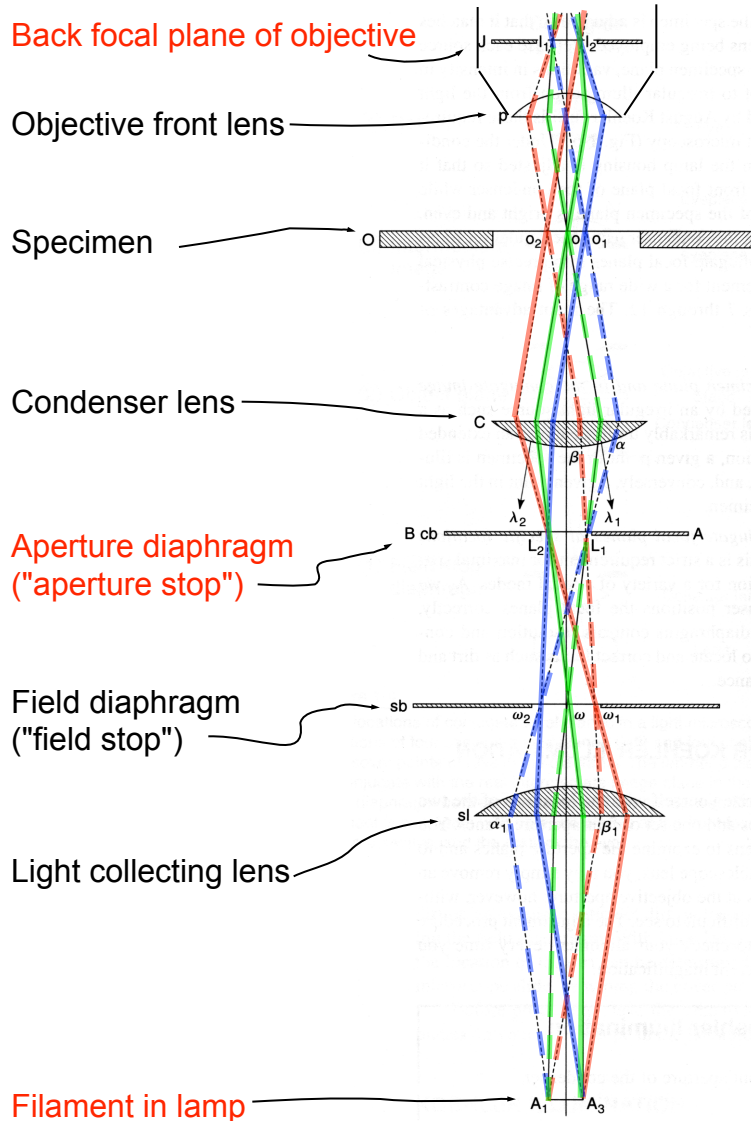

August Kohler  
1866-1948

## CONJUGATE PLANES

- To reduce artifacts, Koehler introduced the light collecting lens and adjusted the condenser position such that the lamp filament is maximally out-of-focus at the specimen plane.
- This innovation is essential to all modern microscopy--the main adjustment we make with transmitted light microscopy is to "Koehler" the microscope by focussing the condenser.
- Koehler illumination highlights a special relationship between two sets of planes in the microscope light path.

# Koehler illumination emphasizes the difference between imaging planes and illumination planes

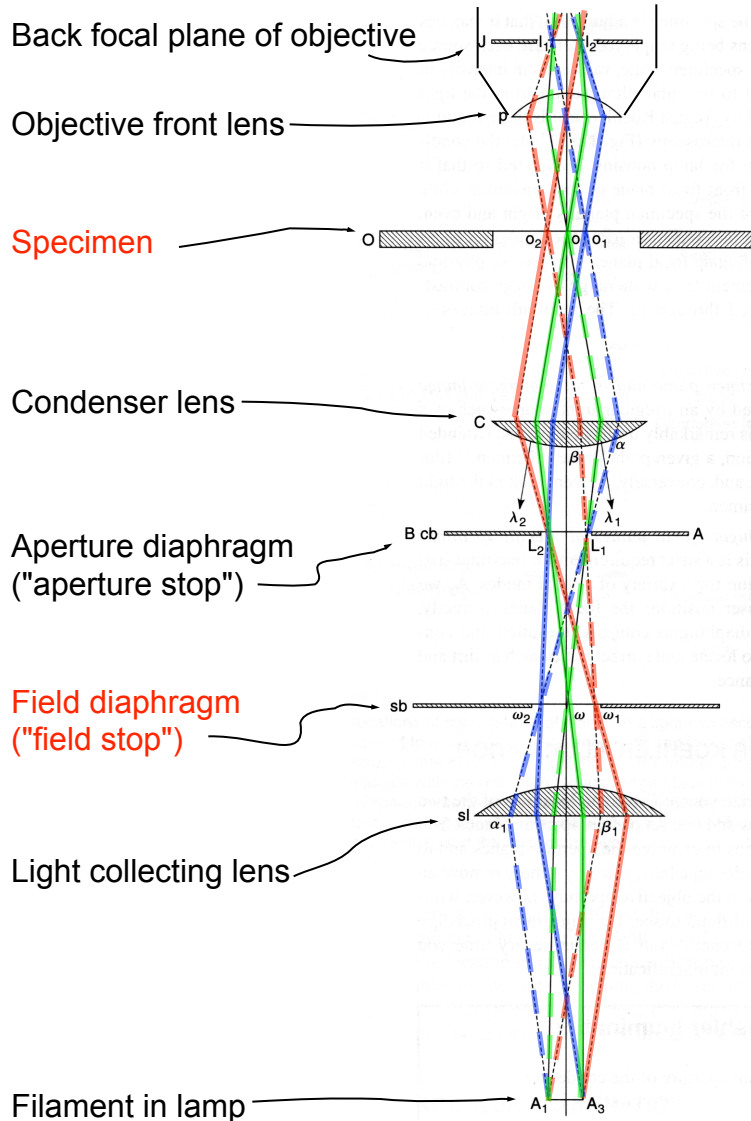

August Kohler  
1866-1948

## CONJUGATE PLANES

- To reduce artifacts, Koehler introduced the light collecting lens and adjusted the condenser position such that the lamp filament is maximally out-of-focus at the specimen plane.
- This innovation is essential to all modern microscopy--the main adjustment we make with transmitted light microscopy is to "Koehler" the microscope by focussing the condenser.
- Koehler illumination highlights a special relationship between two sets of planes in the microscope light path.

# Two sets of conjugate planes in the light microscope

Understanding the reciprocal relationship between the two sets of conjugate planes is crucial for properly understanding:

- Image formation
- Image resolution
- How phase-contrast and DIC work

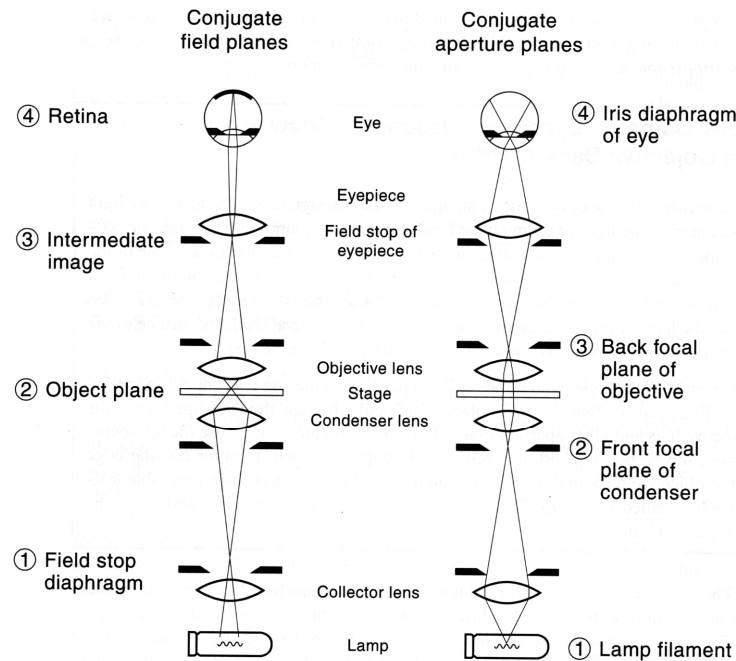

Figure 1-4

The locations of conjugate focal planes in a light microscope adjusted for Koehler illumination. Note the locations of four conjugate field planes (left) and four conjugate aperture planes (right) indicated by the crossover points of rays in the diagrams. The left-hand diagram shows that the specimen or object plane is conjugate with the real intermediate image plane in the eyepiece, the retina of the eye, and the field stop diaphragm between the lamp and the condenser. The right-hand drawing shows that the lamp filament is conjugate with aperture planes at the front focal plane of the condenser, the back focal plane of the objective, and the pupil of the eye.

Conjugate planes are "parfocal" with each other

When something is in focus in one set of conjugate planes, it is "maximally out-of-focus" in the other set of planes

These two sets are often called "reciprocal" or "transform" planes (with respect to each other)

# Diffraction of waves

- Scattering, altering the shape of the wave front
- At left, plane waves in water obtain a circular wavefront after passing through an aperture
- The angle of scattering of light by particles is inversely proportional to the particle size/spacing.

Wavelength  
much smaller  
than aperture

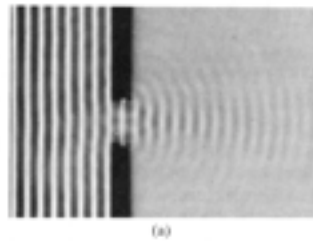

(a)

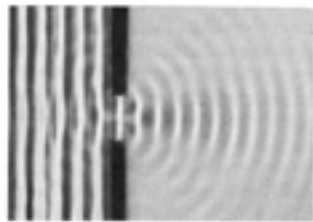

(b)

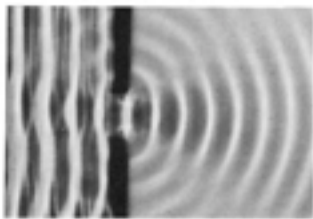

(c)

Wavelength  
comparable to  
aperture

Figure 10.2 Diffraction through an aperture with varying  $\lambda$  as seen in a ripple tank. (Photo courtesy PSSC Physics, D. C. Heath, Boston, 1960.)

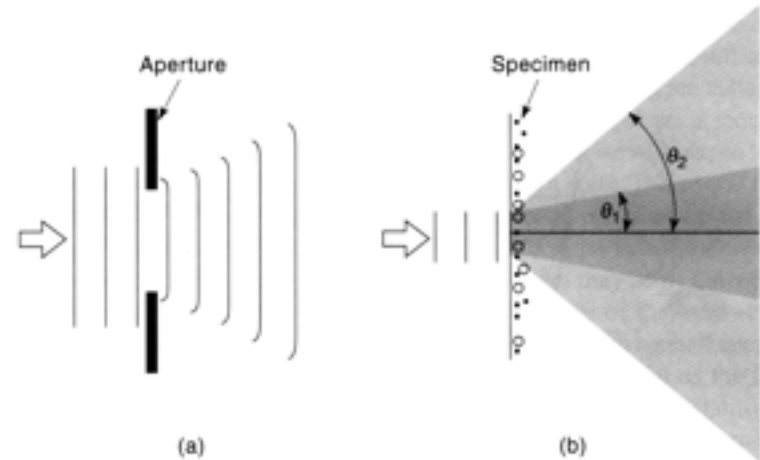

Figure 5-2

Diffraction at an aperture and at a substrate containing fine particles. (a) The electric field of a planar wavefront becomes disturbed by diffraction upon passage through an aperture. The waves appear to grab hold of the aperture and swing around into its geometric shadow. The amplitude profile of a transmitted wavefront is also no longer uniform and remains permanently altered after passage through the aperture (not shown). (b) A substrate containing a layer of a mixture of fine particles (0.2 and 2  $\mu\text{m}$  diameter) diffracts an incident planar wavefront into scattered beams that diverge at different angles. The angle of spreading ( $\theta$ ) is inversely proportional to the size of the particles.

# Diffraction and interference

- Prelude to the "two-slit" experiment
- When there are multiple sources, interference can occur

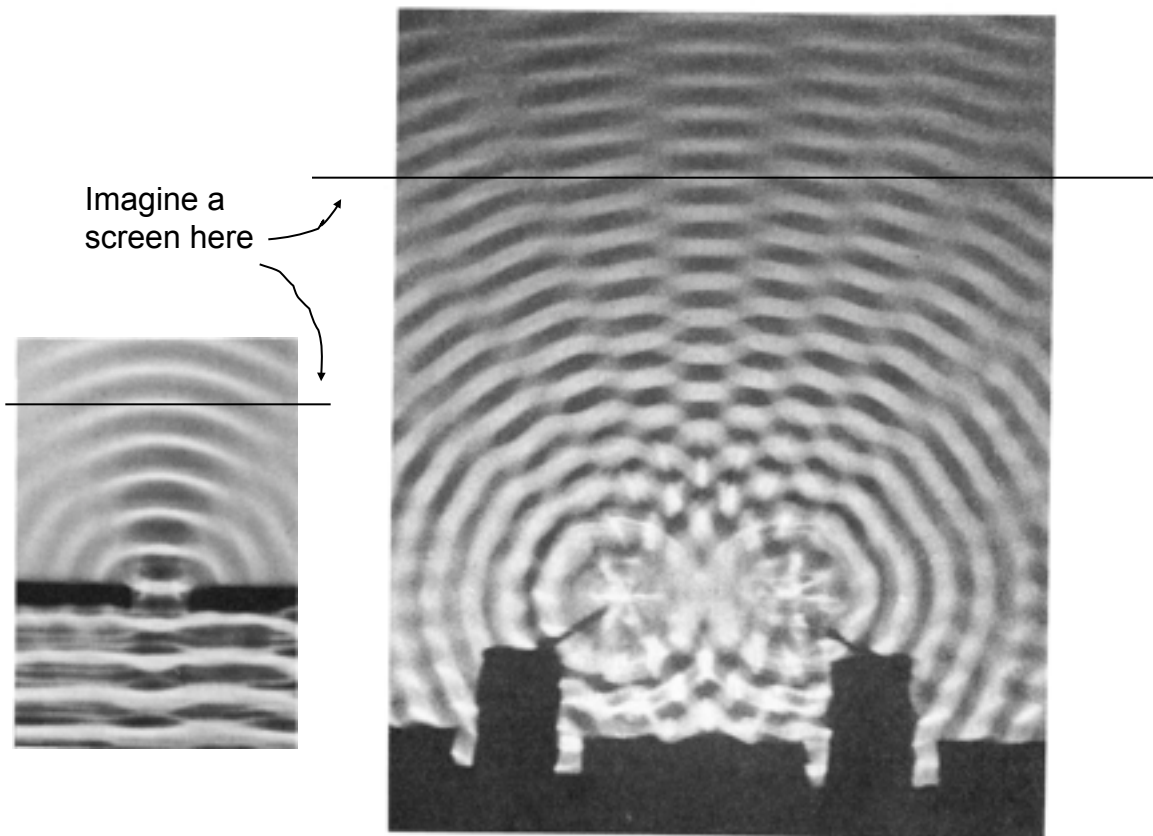

Figure 9.1 Water waves from two point sources in a ripple tank.

## Constructive and destructive interference

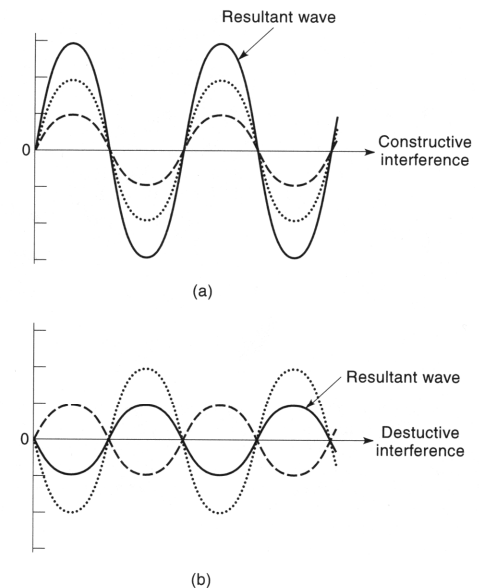

Figure 5-3

Two coincident waves can interfere if their E vectors vibrate in the same plane at their point of intersection. Two waves are shown that vibrate in the plane of the page. In these examples, both waves (dotted and dashed curves) have the same wavelength, but vary in amplitude. The amplitude of a resultant wave (solid curve) is the arithmetic sum of the amplitudes of the two original waves. (a) Constructive interference occurs for two waves having the same phase. (b) Destructive interference occurs for waves shifted in phase; if the amplitudes of the waves are the same and the relative phase shift is  $\lambda/2$ , the wave is eliminated.



# Young's demonstration of the wave nature of light

- Demonstrated that Newton's theory of light "corpuscles" was wrong, or at least incomplete
- The diffraction pattern obtained with both slits open could be explained only by interference of waves

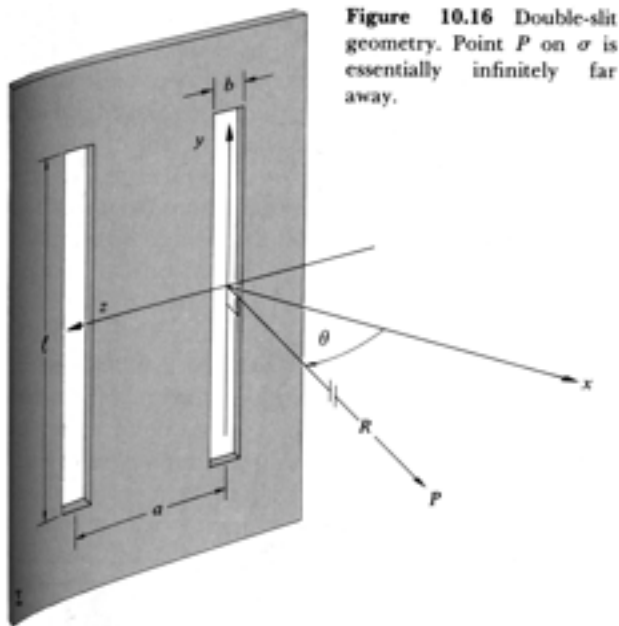

Figure 10.16 Double-slit geometry. Point  $P$  on  $\sigma$  is essentially infinitely far away.

Diffraction pattern from a single slit open

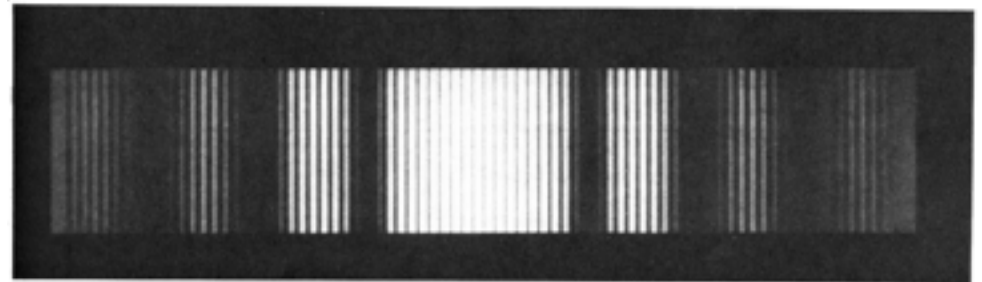
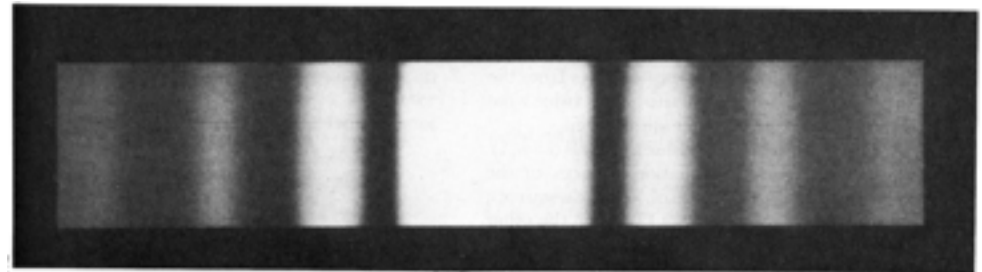

Figure 10.17 Single- and double-slit Fraunhofer patterns. The faint cross-hatching arises entirely in the printing process. (Photos courtesy M. Cagnet, M. Francon, and J. C. Thierri: *Atlas optique des Enregistrements*, Berlin-Heidelberg-New York: Springer, 1962.)

Diffraction pattern from both slits open

The fine spacing of the lines is inversely related to the distance "a" between the two slits

# Analogy to X-ray diffraction

- Diffraction patterns contain information about the spatial distribution of sub-structures in an unusual way
- Spots represent interference of scattered waves
- Spots far from the origin represent interference of waves scattered from closely neighboring points (e.g. Joe Crystallographer says, "my crystals diffract at  $1/\lambda$ ,  $2/\lambda$ , &  $3/\lambda$ ")

**Figure 18.5** Schematic view of a diffraction experiment. (a) A narrow beam of x-rays (red) is taken out from the x-ray source through a collimating device. When the primary beam hits the crystal, most of it passes straight through, but some is diffracted by the crystal. These diffracted beams, which leave the crystal in many different directions, are recorded on a detector, either a piece of x-ray film or an area detector. (b) A diffraction pattern from a crystal of the enzyme RuBisCo using monochromatic radiation (compare with Figure 18.2b, the pattern using polychromatic radiation). The crystal was rotated one degree while this pattern was recorded.

**Figure 18.14** The diffraction pattern of helices in fiber crystallites can be simulated by the diffraction pattern of a single slit with the shape of a sine curve (representing the projection of a helix). Two such simulations are given in (a) and (b), with the helix shown to the left of its diffraction pattern. The spacing between the layer lines is inversely related to the helix pitch,  $P$  and the angle of the cross arms in the diffraction pattern is related to the angle of climb of the helix,  $\theta$ . The helix in (b) has a smaller pitch and angle of climb than the helix in (a). (Courtesy of W. Fuller.)

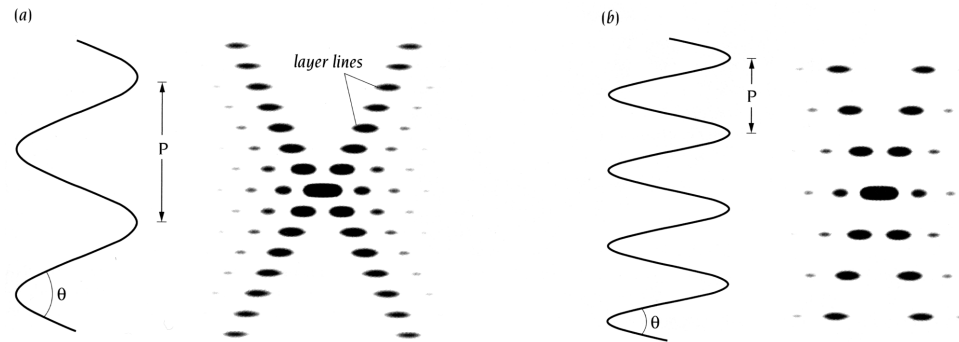

Spacing of layer lines is inversely proportional to the periodicity



# Anything can create a diffraction pattern

- The individual spots in diffraction patterns of protein crystals are particularly prominent because the protein crystals have the same structure repeated infinitely, but even individual objects generate diffraction patterns (which are even more complex)

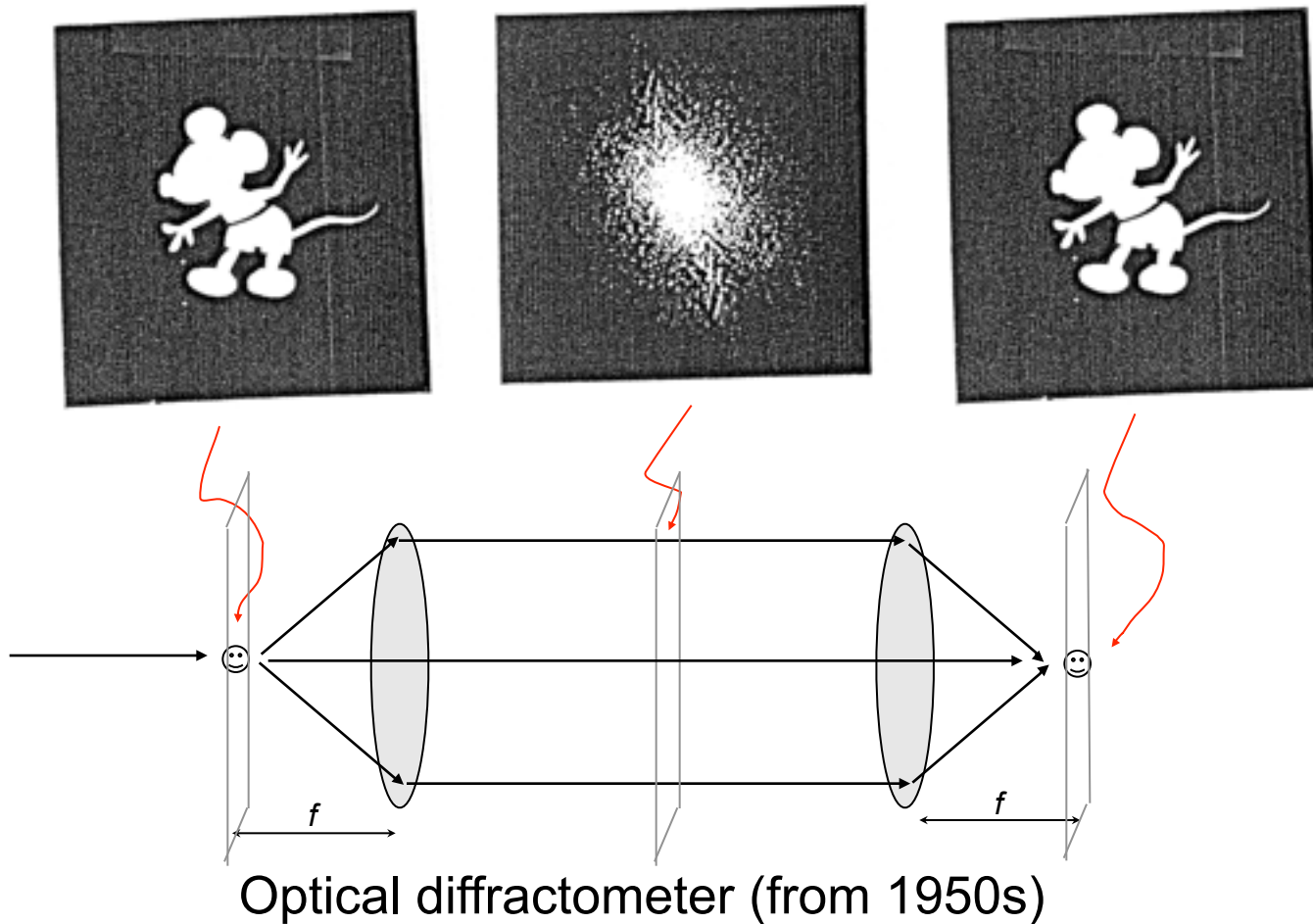

# Abbe's theory of image formation

Ernst Abbe, 1840–1905. Principles of microscope and objective lens design, the theory of image formation in the microscope, and standardized lens manufacturing procedures all trace their beginnings to the work of Ernst Abbe and his collaborations with Carl Zeiss in Jena, Germany, in the 1860s. Until then, lens making was an art and a craft, but the new industrial philosophy demanded technical perfection, lens designs based on theory and research, and improvements in raw materials. At Abbe's initiative, lens curvatures were examined using an interference test with Newton's rings, and lens designs were based on Abbe's sine-squared condition to remove aberrations. He created the first planachromatic lens, and after much research, the apochromatic lens, which was commercially sold in 1886. After many false starts over a 20-year period, the research-theory-testing approach for manufacturing lenses proved to be successful. These improvements and new photographic lens designs required new types of glass with values of refractive index and color dispersion that were not then available. Abbe and Zeiss won grants and developed new glasses in collaborations with the industrialist, Otto Schott, owner of the Jena Glassworks. Other inventions were the Abbe achromatic condenser, compensating eyepieces for removing residual color aberration, and many other significant items of optical testing equipment. Abbe is perhaps most famous for his extensive research on microscope image formation and his diffraction theory, which was published in 1873 and 1877. Using a diffraction grating, he demonstrated that image formation requires the collection of diffracted specimen rays by the objective lens and interference of these rays in the image plane. By manipulating the diffraction pattern in the back aperture, he could affect the appearance of the image. Abbe's theory has been summarized as follows: *The microscope image is the interference effect of a diffraction phenomenon.* Abbe also introduced the concept of numerical aperture ( $n \sin \theta$ ) and demonstrated the importance of angular aperture on spatial resolution. It took 50 years for his theory to become universally accepted, and it has remained the foundation of microscope optical theory ever since. Ernst Abbe was also a quiet but active social reformer. At the Zeiss Optical Works, he introduced unheard-of reforms, including the 8-hour day, sick benefits, and paid vacations. Upon his death, the company was handed over to the Carl Zeiss Foundation, of which the workers were part owners.



Figure 5-13

# The diffraction grating

- The grating is a series of ruled lines, spaced very close together (e.g.  $1000 \text{ nm} = 1 \mu\text{m}$ ), roughly in the neighborhood of the wavelength of light
- Gratings are made by machining (difficult) or by laser etching, or more often as plastic replicas of originals
- Gratings can be either transmission gratings (as shown) or reflection gratings (e.g. machined on a piece of metal).

Diffraction by an actual grating.  
Each of the different orders is  
"made up" of parallel rays  
(converging only at infinity)

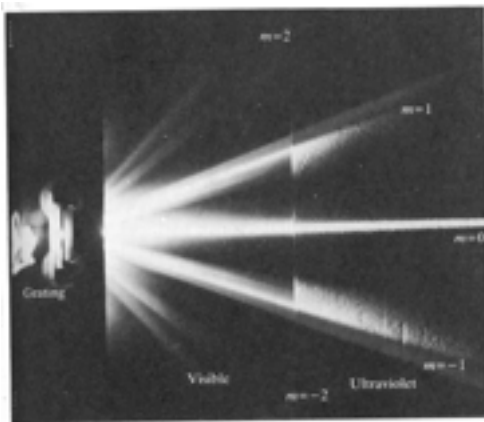

Figure 10.55 Light passing through a grating. The region on the left is the visible spectrum, that on the right, the ultraviolet. (Photo courtesy Klinger Scientific Apparatus Corp.)

Addition of a lens to the system allows the spots to be nicely in focus at a finite distance from the grating

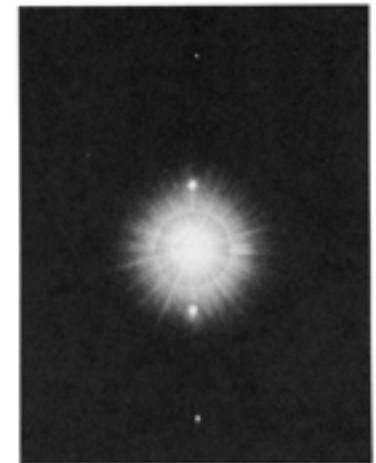
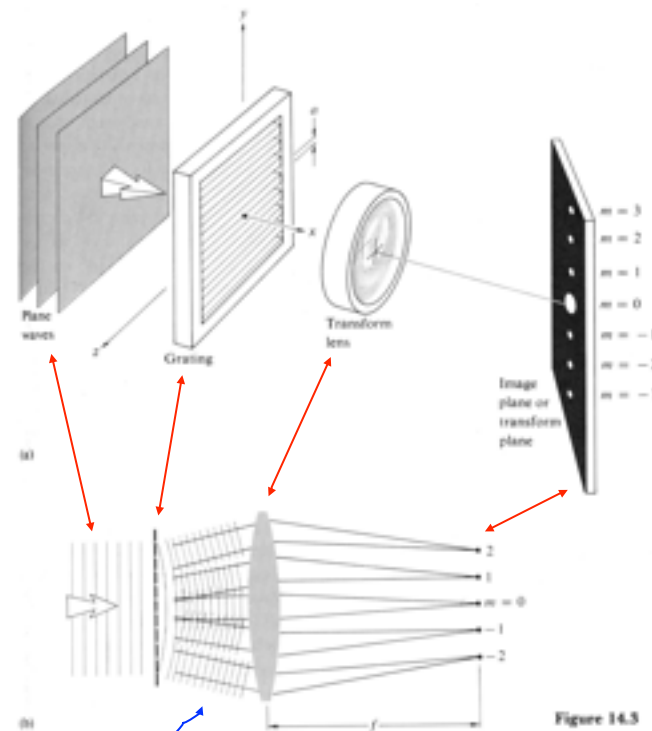

Figure 14.3 Diffraction pattern of a grating. (Source unknown.)

# Diffraction by a grating

Abbe's experiments with gratings helped him to develop his theory of image formation, which is what we use today.

$$d \sin \theta = n \lambda$$

(where  $n = 0, 1, 2$ , etc.)

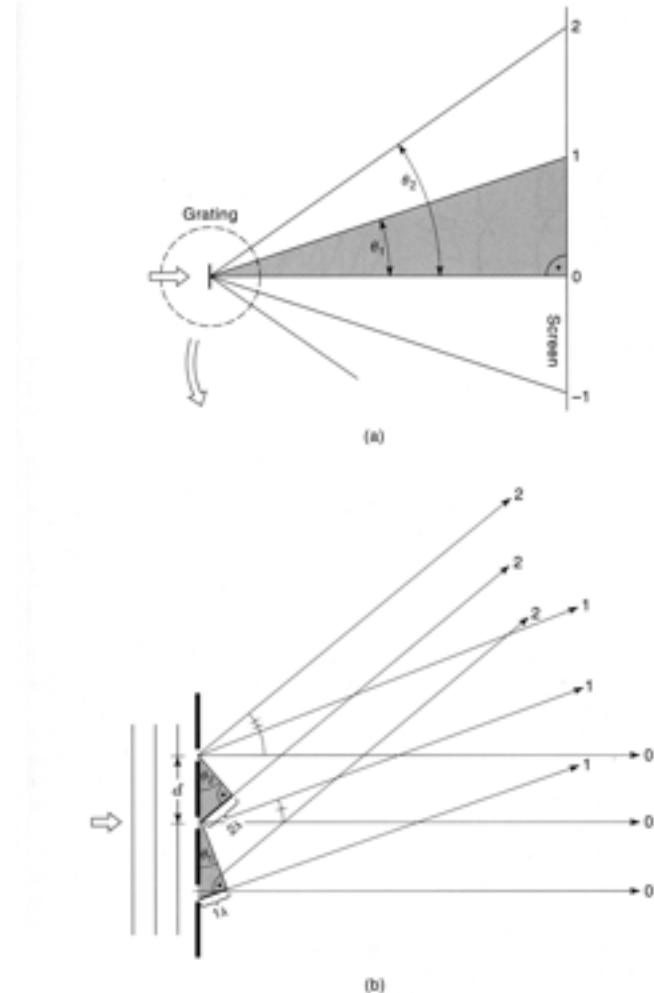

Figure 5-9  
Dependence of scattering angle on grating spacing and wavelength. (a) Rays from a diffraction grating projected on a viewing screen. The angle of scattering of the 1<sup>st</sup>- and 2<sup>nd</sup>-order rays is shown as  $\theta_1$  and  $\theta_2$ . The grating and 1<sup>st</sup>- and 2<sup>nd</sup>-order spots define a right triangle that includes  $\theta_1$ , and is congruent with a triangle that can be delineated at the grating as shown in (b). (b) The diffracted rays at the grating define a right triangle that includes diffraction angle  $\theta$ . For the 1<sup>st</sup>- and 2<sup>nd</sup>- etc.-order diffracted rays, the base of the triangle is an integral number of wavelengths,  $1\lambda$ ,  $2\lambda$  etc. Thus, the angle of diffraction depends on two parameters: the grating spacing  $d$  and wavelength  $\lambda$ .

# Abbe theory

Abbe's big idea: "The microscope image is the interference effect of a diffraction phenomenon"

Image formation depends on interference between non-diffracted light (0th order) and diffracted light (1st order and higher order as well)

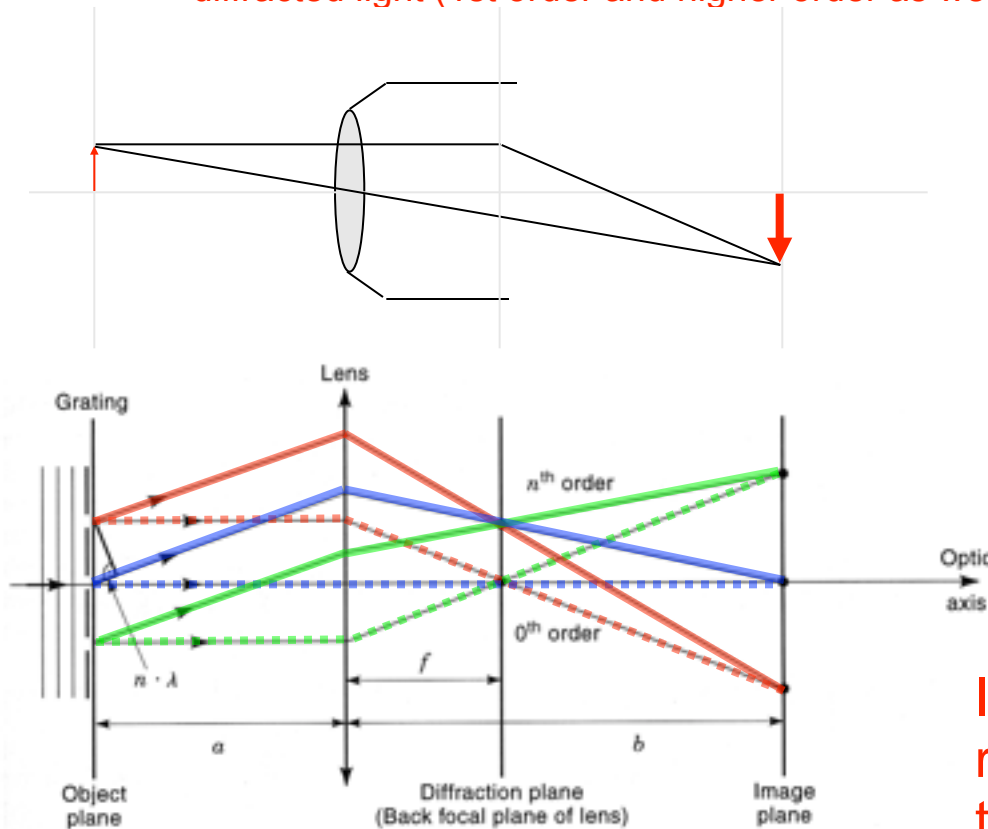

Figure 5-14

Abbe's theory for image formation in a light microscope. An objective lens focused on a grating ( $2f > a > f$ ) in the object plane produces a magnified real image of the grating in the image plane. The diffraction plane is located at  $1f$  in the back aperture of the lens. An incident planar wavefront is shown. Diffracted  $n$ th-order and nondiffracted 0th-order rays are separated in the diffraction plane, but are combined in the image plane.

## Interference

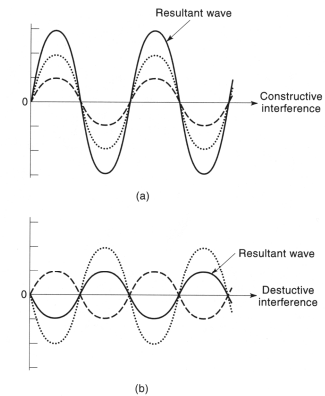

Figure 5-3

Two coincident waves can interfere if their E vectors vibrate in the same plane at their point of intersection. Two waves are shown that vibrate in the plane of the page. In these examples, both waves (dotted and dashed curves) have the same wavelength, but vary in amplitude. The amplitude of a resultant wave (solid curve) is the arithmetic sum of the amplitudes of the two original waves. (a) Constructive interference occurs for two waves having the same phase. (b) Destructive interference occurs for waves shifted in phase; if the amplitudes of the waves are the same and the relative phase shift is  $\lambda/2$ , the wave is eliminated.

In this sense, a lens serves to recombine light diffracted from the specimen such that the diffracted light interferes with itself in a manner that recreates an image of the specimen

# Diffraction from closer spacing is at higher angles

- So if two substructures in an object are very close together, the "information" about their relative closeness will be a "high-angle" diffraction spot, i.e., further away from the undiffracted, 0th order spot.
- To get "high-resolution" images recreated from the diffraction spots, we need to collect the high-angle diffracted scattering

$$d \sin \theta = n \lambda$$

(in this instance, only  $n = 1$  is shown)

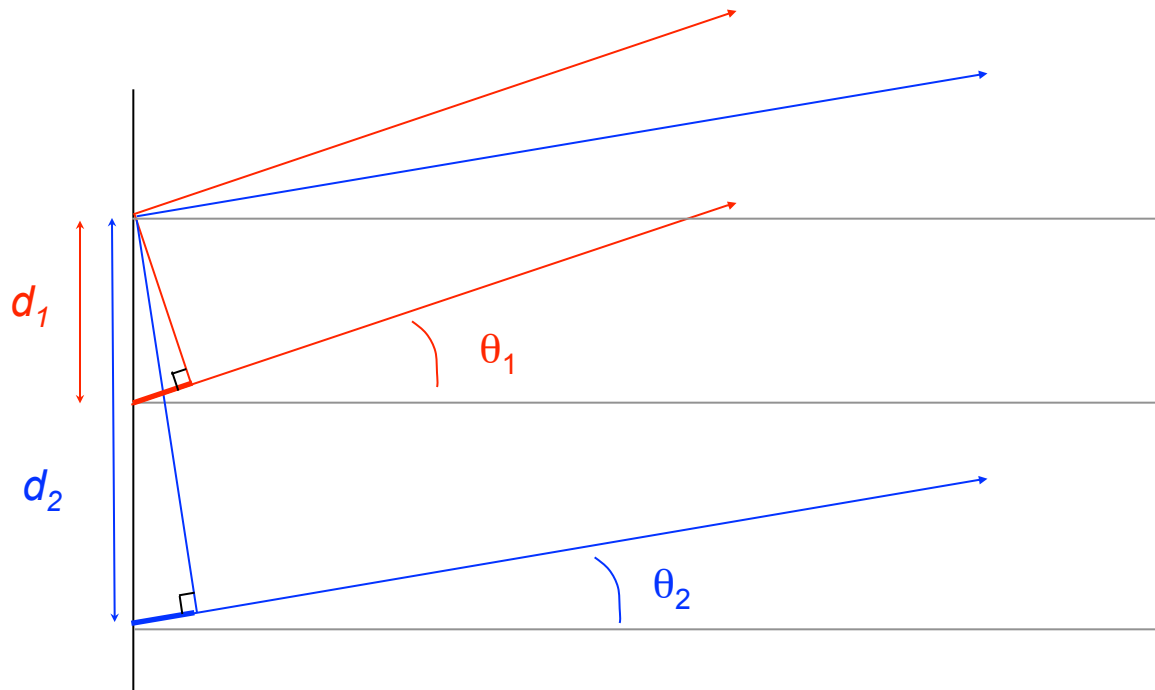

# Getting the highest resolution image depends on capturing the largest angle of scattered light

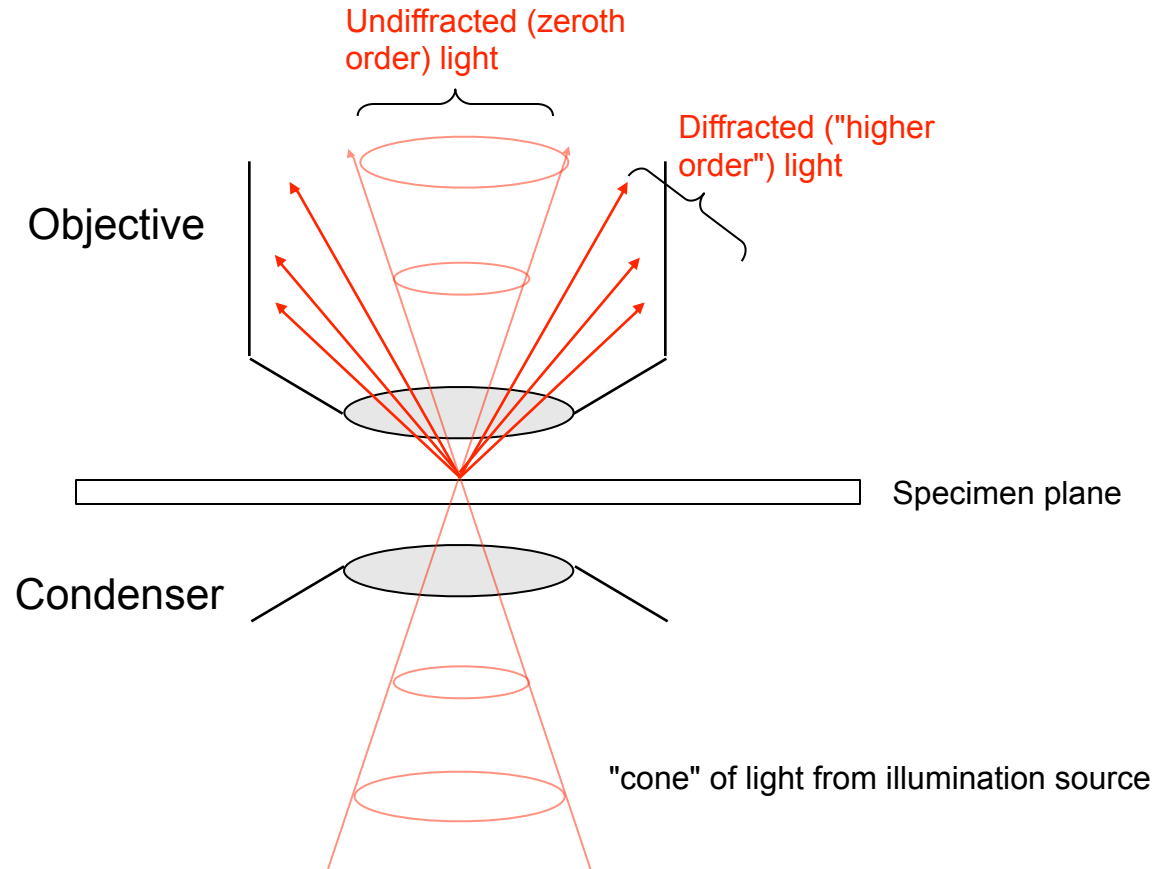

# Removing higher-orders of the diffraction pattern reduces the resolution of the resulting image

- A mask is included at the diffraction plane to allow only the zeroth order and lower-order light to pass through

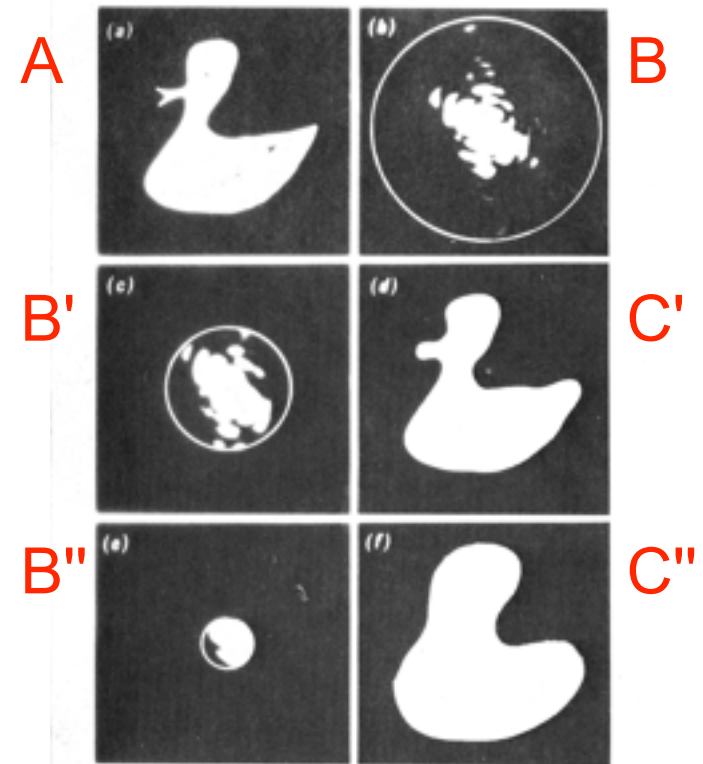
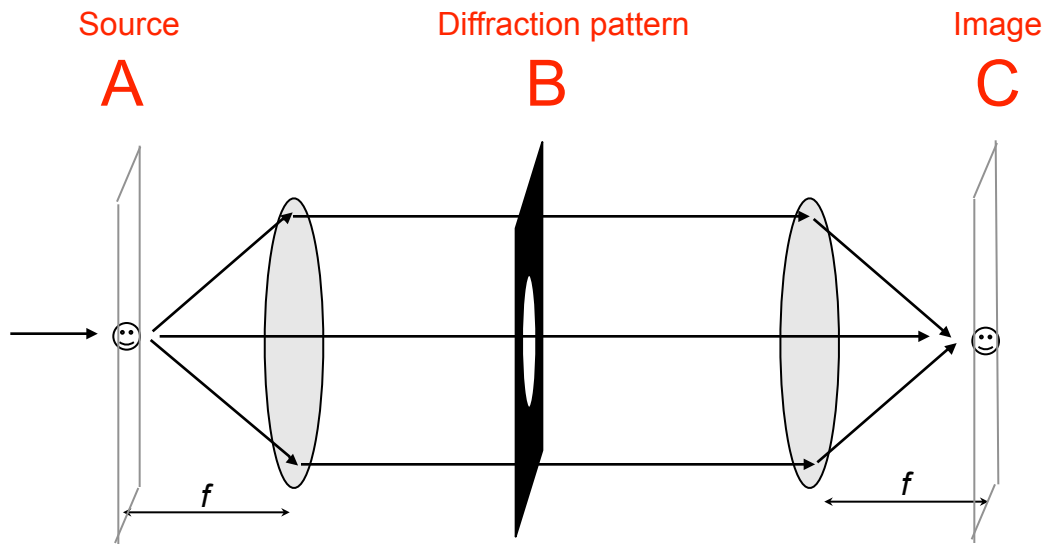

Fig. 3. The effect of taking only low angle diffraction to form the image of an object. A drawing of a duck is shown, together with its diffraction pattern. Also shown are the images formed (as the diffraction pattern of the diffraction pattern) when stops are used to cut out progressively more of the high angle diffraction pattern. [We are grateful to Dr. C. A. Taylor and Professor H. Lipson for permission to reproduce this diagram (170).]



# Fourier Transforms (FTs) a quick intro

# Basis of Fourier's ideas.

- Any function can be composed of a sum of simple sine waves.
- Each sine wave then has a frequency and phase.
- Summing all these sine wave together creates the final function.
- Summing a limited number will create an imperfect representation of the function.

# A simple ID example



- a square wave can be made by adding...

# Fourier transforms of images.

Image with 1  
Fourier  
component in  
each direction



+



# Fourier transforms of images.

Image with 2  
Fourier  
components in  
each direction



+

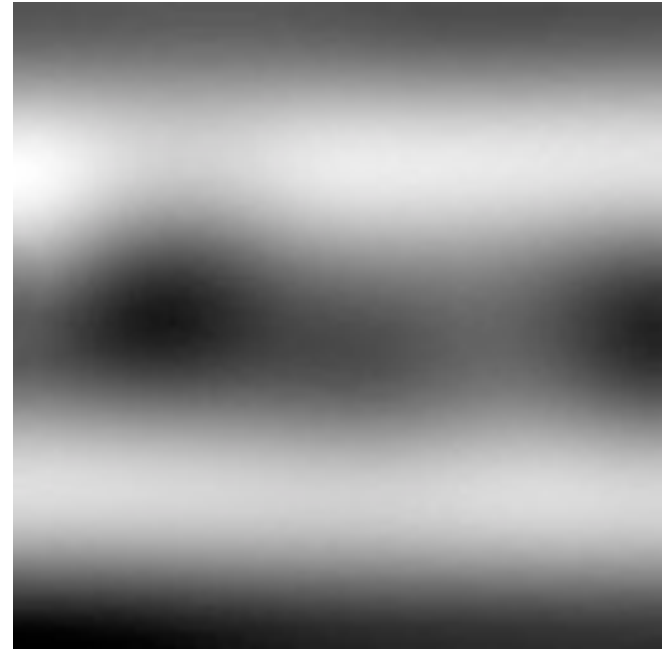

# Fourier transforms of images.

Image with 3  
Fourier  
components in  
each direction



# Fourier transforms of images.



# Fourier transforms of images.





# Fourier transforms of images.



# Fourier transforms of images.



# Fourier transforms of images.



# Fourier transforms of images.



# The full Fourier Transform



Fourier  
→  
Transform

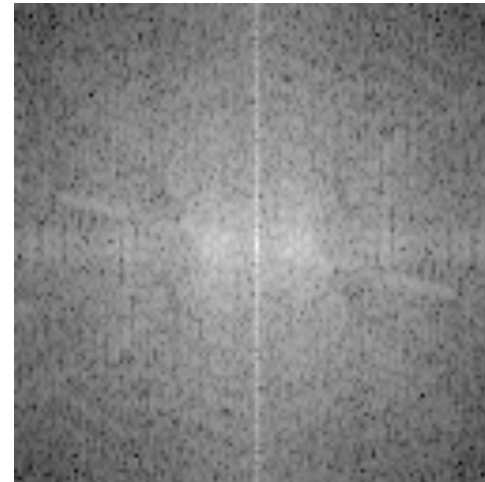



Fourier  
Transform 

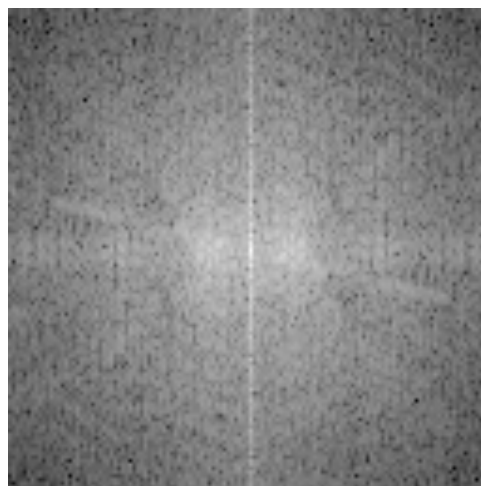

Intensity Image

+

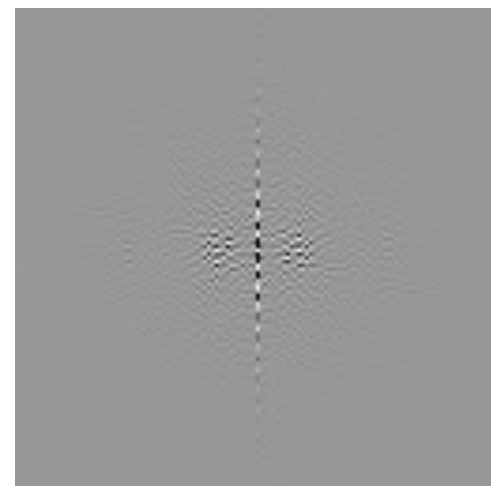

Phase Image

# FFT of a real image

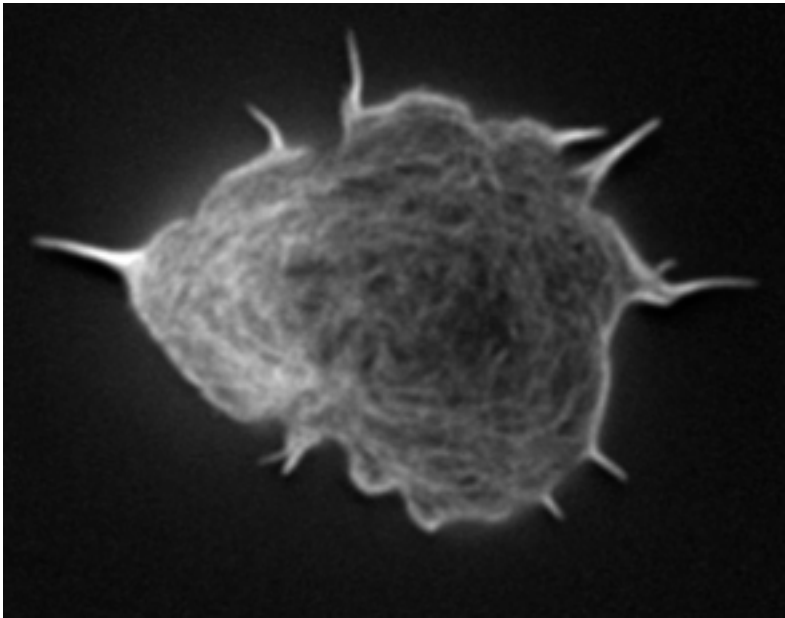

Image

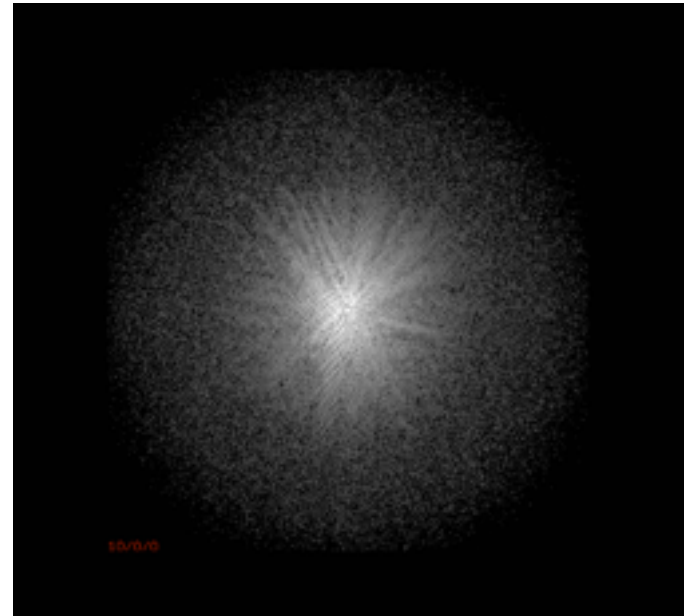

Fourier Transform  
(intensity image)

# A few technical points.

- As the image has discrete pixels, this is a Discrete Fourier Transform (DFT) and you DON'T need an infinite series
- Every point in the image contributes to every point in the transform and vice-versa.
- BUT certain features in the transform contribute to certain features of the image



# Numerical aperture (N.A.) and wavelength determine resolution

Resolution--the ability to distinguish two point sources of light--is typically 250-300 nm, depending on wavelength, etc.

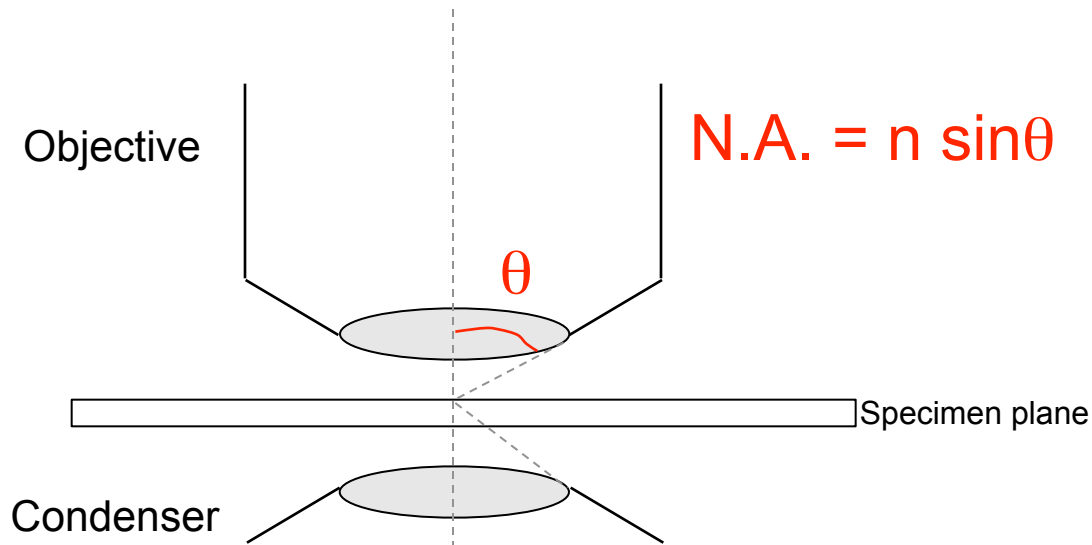

$$\text{resolution} = 0.61\lambda / N.A.$$

$$\text{More correctly, } N.A. \text{ of system} = N.A._{(obj)} + N.A._{(cond)} / 2$$

Over 100 years old!

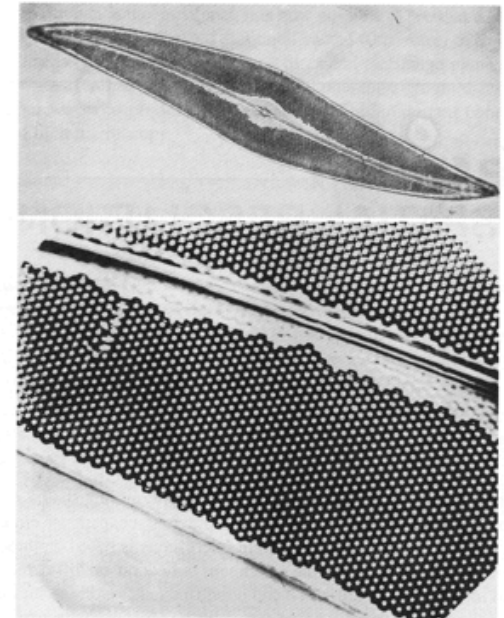

Figure 6-1

Resolution of the pores in a diatom shell with an apochromatic objective lens. Joseph Gall described these historic photographs of the diatom *Pleurosigma* prepared over 100 years ago using one of Abbe's lenses (*Molecular Biology of the Cell*, vol. 4, no. 10, 1993). "The photographs . . . are taken from a Zeiss catalog published in 1888 in which Abbe's apochromatic objectives were advertised. Both figures show the silica shell of the diatom *Pleurosigma angulatum*. Because of the regular patterns of minute holes in their shells, diatoms have long been favorite objects for testing the resolution of microscope objectives. The top figure shows an entire shell at 500 $\times$ , a magnification beyond which many 19th-century objectives would show little additional detail. The bottom figure, reproduced here and in the original catalog at a remarkable 4900 $\times$ , was made with an apochromatic oil immersion objective of 2.0 mm focal length and a numerical aperture of 1.3. The center-to-center spacing of the holes in the shell is 0.65  $\mu\text{m}$ , and the diameter of the holes themselves is about 0.40  $\mu\text{m}$ . Almost certainly this objective resolved down to its theoretical limit of 0.26  $\mu\text{m}$  in green light."

# N.A. and resolution

- The condenser should not be ignored when considering resolution

For highest resolution, open the condenser to fill the back focal plane

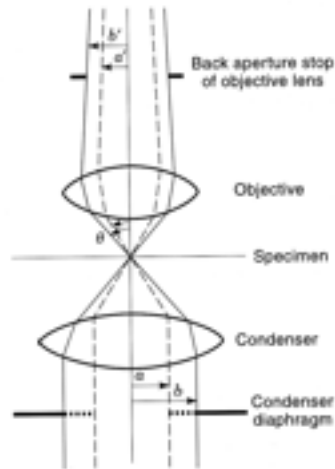

Figure 6-4

Role of the condenser diaphragm in determining the effective numerical aperture. Closing the front aperture diaphragm of the condenser from position  $b$  to  $a$  limits the angle  $\theta$  of the illumination cone reaching the objective, and thus the effective numerical aperture. Notice that the back aperture of the objective is no longer filled at the reduced setting.

Condenser open

Condenser closed

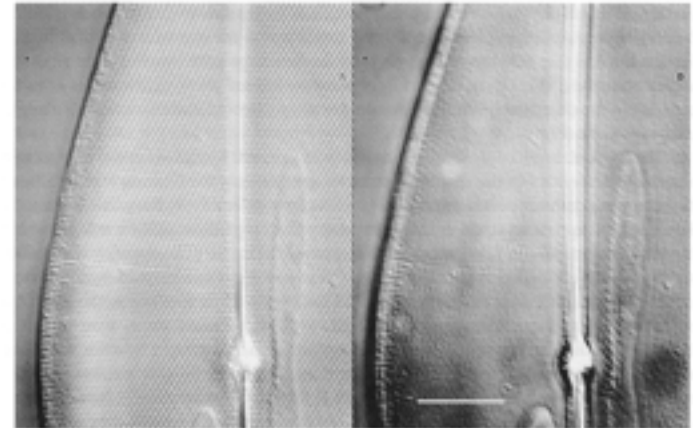

Figure 6-5

Effect of numerical aperture on spatial resolution. The diatom *Pleurosigma* photographed with a 25 $\times$ , 0.8 NA oil immersion lens using DIC optics. (a) Condenser aperture open, showing the near hexagonal pattern of pores. (b) The same object with the condenser diaphragm closed. The 1st-order diffracted rays from the pores are not captured by the objective with a narrow cone of illumination. Spatial resolution is reduced, and the pores are not resolved. Bar = 10  $\mu\text{m}$ .

Different types of condensers

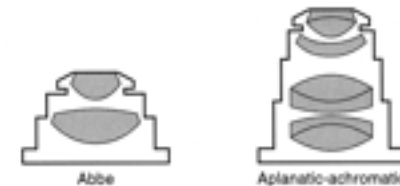
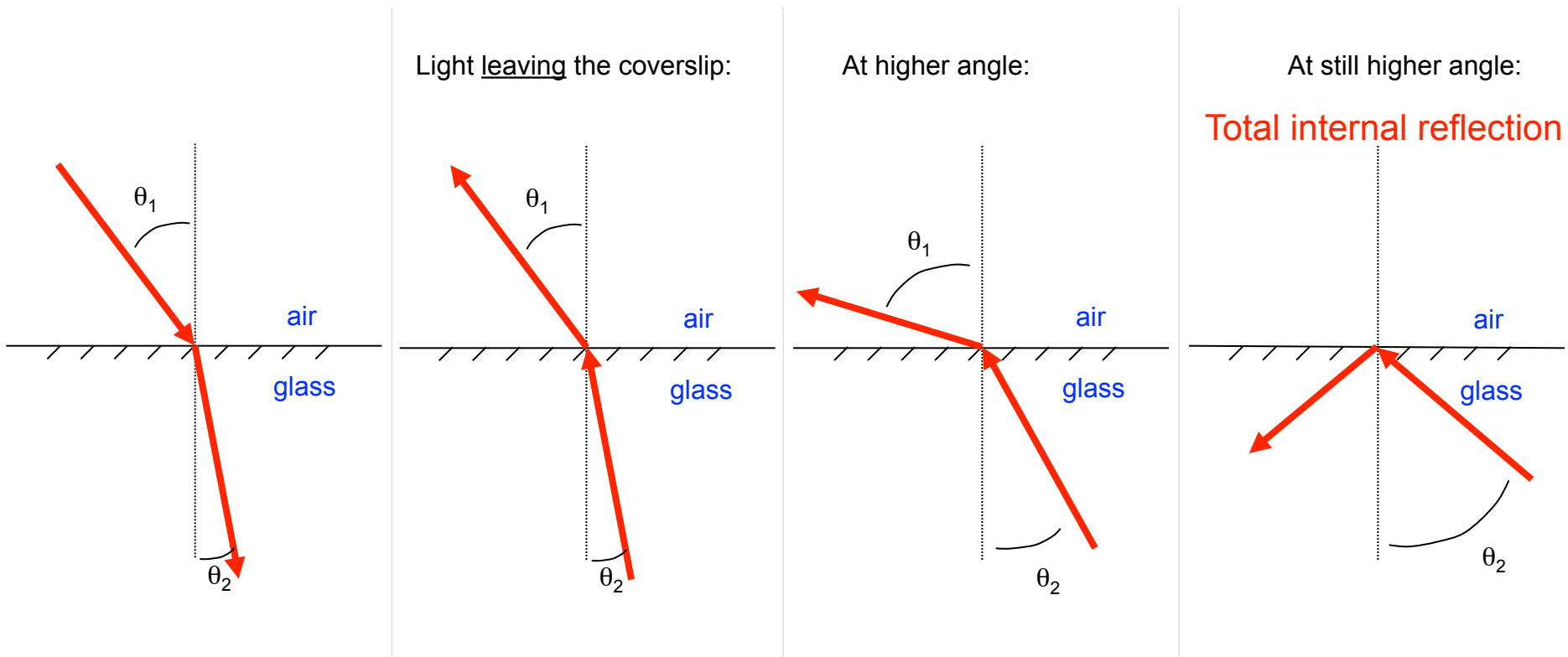

Figure 4-11

Two common microscope condensers. The Abbe condenser contains two achromatic doublet lenses and gives very good performance for dry lenses of low to medium power. The achromatic-aplanatic condenser is useful for lenses with  $\text{NA} > 0.5$ , and is essential for oil immersion lenses with high numerical apertures. For low NA performance, the top element of this condenser can be removed. This condenser focuses light in a flat focal plane and is highly corrected for the significant lens aberrations.

# Why we use immersion oil with high-power objectives

- In fact, immersion oil can also be used with relatively low power objectives (e.g. 25X).
- But with high power objectives, magnification without resolution is useless, so the N.A. must be maximized
- Refraction of light leaving the specimen, passing through a coverslip, and reaching the coverllip-air interface is the problem--total internal reflection



# Why we use immersion oil with high-power objectives

- In fact, immersion oil can also be used with relatively low power objectives (e.g. 25X).
- But with high power objectives, magnification without resolution is useless, so the N.A. must be maximised
- Refraction of light leaving the specimen, passing through a coverslip, and reaching the coverslip-air interface is the problem--total internal reflection

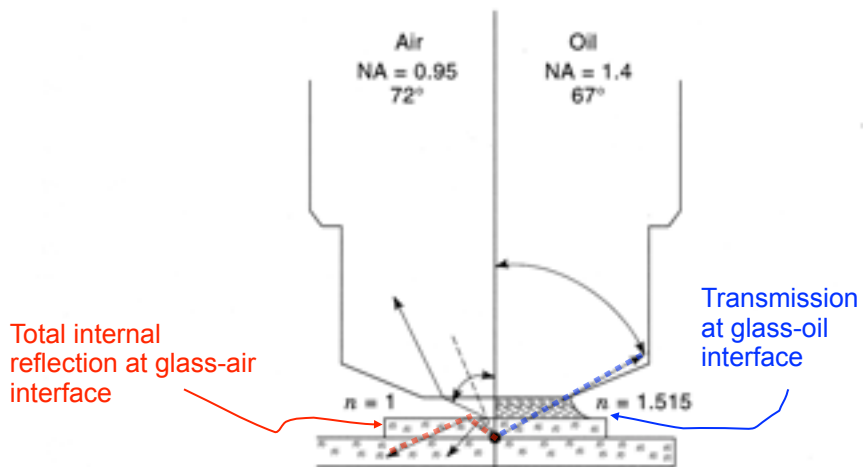

Figure 6-2

Effect of immersion oil on increasing the angular extent over which diffracted rays can be accepted by an objective lens. Numerical aperture is directly dependent on the wavelength  $\lambda$  and the sine of the half angle of the cone of illumination  $\theta$  accepted by the front lens of the objective. For dry lenses, NA is limited, because rays subtending angles of  $41^\circ$  or greater are lost by total internal reflection and never enter the lens (dotted line). The practical limit for a dry lens is  $\sim 39^\circ$ , which corresponds to an acceptance angle of  $72^\circ$ , and an NA of 0.95. By adding high-refractive index immersion oil matching that of the glass coverslip ( $n = 1.515$ ), an oil immersion objective can collect light diffracted up to  $67^\circ$ , which corresponds to NA = 1.4.

•The "standard" coverslips are "thickness 1.5", which are 0.16-0.19 mm thick

•"thickness 1" coverslips are quite thin, and tend to break easily--don't buy them!

•Changing coverslips or refractive index of immersion oil can help for very high-resolution or special-purpose imaging

# Reading objective markings--a field guide

- All modern microscopes for the last ~15 years (Zeiss, Nikon, Olympus, Leica) use "infinity-corrected" optics rather than standard 160 mm tubelength optics (RMS standard). Older and/or cheaper scopes may still use the RMS standard
- With old (RMS) standard, objectives were completely interchangeable
- With new standards, companies have gone their separate ways, and the optics can be fundamentally different (and threads are often not compatible anyhow).



Mag.	1X	2X	4X	10X	20X	40X	50X	60X	100X
Color code	Black	Gray	Red	Yellow	Green	Light blue	Light blue	Dark blue	White

Figure 4-10

Key for interpreting the markings on the barrel of an objective lens. Markings on the lens barrel indicate the type of lens and correction, initial magnification, immersion medium, numerical aperture, lens-image distance, and required coverglass thickness. For quick reference, the color-coded ring, near the thread, denotes the initial magnification, while the color-coded ring near the front lens denotes the type of immersion medium (black-immersion oil, white-water, orange-glycerin, yellow-methylene iodide, red-multi-immersion).

# Key points

- Basic understanding of refraction and diffraction, and properties of lenses
- Understanding of two different sets of conjugate planes, especially importance of objective back-focal plane
- Understanding of factors affecting image resolution

# References

- D.B. Murphy, Fundamentals of Light Microscopy and Electronic Imaging
- E. Hecht, Optics
- [www.micron.ox.ac.uk](http://www.micron.ox.ac.uk)
  
- M. Spencer, Fundamentals of Light Microscopy (older but still useful)